



**CONSOLIDATED EDISON CO. OF NEW YORK, INC.  
4 IRVING PLACE  
NEW YORK, NY 10003**

**DISTRIBUTION ENGINEERING DEPARTMENT  
NETWORK SYSTEMS SECTION**

**SPECIFICATION EO-2022  
REVISION 15  
DECEMBER 2009**

**EFFECTIVE DATE  
DECEMBER 31, 2009**

**GENERAL SPECIFICATION FOR HIGH TENSION SERVICE**

**FIELD MANUAL No. 16, SECTION 4**

<b>TARGET AUDIENCE</b>	<b>DISTRIBUTION ENGINEERING ENERGY SERVICES SYSTEM OPERATIONS REVENUE METERING</b>
<b>NESC REFERENCE 2002</b>	<b>ALL</b>

## TABLE OF CONTENTS

<u>Paragraph</u>	<u>Description</u>
1.0	<b><u>PURPOSE</u></b>
2.0	<b><u>APPLICATION</u></b>
3.0	<b><u>DEFINITIONS</u></b>
3.1	Customer and Company
3.2	Company Service Type and Voltage
3.3	Customer Utilization Voltage
3.4	Contingencies
3.5	Feeder Bands
3.6	Primary Service Feeder Lineup
3.7	Electrical Equipment Rooms
3.8	Switchgear
3.9	Switchgear Room
3.10	Transformer Room
3.11	Transformer Vault
4.0	<b><u>GENERAL</u></b>
4.1	Customer Data
4.2	General & Technical Specifications
4.3	Service Availability
5.0	<b><u>RADIAL DESIGN CONFIGURATION</u></b>
5.1	Radial Design
5.2	Relay Protection
5.3	Manual and Automatic Load Shifting

---

<b>Specification</b>	<b>Revision</b>	<b>Rev Date</b>	<b>Effective Date</b>	<b>Copyright Information</b>	<b>Page</b>
EO – 2022	15		12/31/2009	1966-2009 Consolidated Edison Co. of New York, Inc.	2/81
<b>Filing Information</b>		Application and Design		Manual No. 4	

Paper copies of procedures and instructions are uncontrolled and therefore may be outdated. Please consult Distribution Engineering Intranet Site [Distribution Engineering](#) or <http://distribution>, for the current version prior to use.

## TABLE OF CONTENTS

<u>Paragraph</u>	<u>Description</u>
	5.4 Automatic Transfer Eligibility
	5.5 Automatic Transfer Logic
	5.6 Automatic Transfer Time Delay
	5.7 Transfer of Customer Load Buses
	5.8 Manual Transfer and Retransfer
	5.9 Interlocking System Electrical Controls
	5.10 Grounding
	5.11 G&T Device and Ground Switch
	5.12 Emergency Generators
	5.13 Remote Monitoring and Control
6.0	<b><u>PARALLEL DESIGN CONFIGURATION</u></b>
	6.1 Parallel Design
	6.2 Relay Protection
	6.3 Grounding
	6.4 Emergency Generators
	6.5 Remote Monitoring and Control
7.0	<b><u>SERVICE VAULTS AND COMPARTMENTS</u></b>
	7.1 Items for Review
	7.2 Electrical Equipment Rooms
	7.3 Power Transformers
	7.4 Environmental Issues
	7.4.1 Power Transformer Oil Containment
	7.5 Security Fence and Lighting

---

Specification	Revision	Rev Date	Effective Date	Copyright Information	Page
EO – 2022	15		12/31/2009	1966-2009 Consolidated Edison Co. of New York, Inc.	3 / 81
<b>Filing Information</b>		Application and Design		Manual No. 4	

Paper copies of procedures and instructions are uncontrolled and therefore may be outdated. Please consult Distribution Engineering Intranet Site [Distribution Engineering](#) or <http://distribution>, for the current version prior to use.

## TABLE OF CONTENTS

<u>Paragraph</u>	<u>Description</u>
8.0	<b><u>PRIMARY SERVICE FEEDERS</u></b>
8.1	Underground Feeders
8.2	Overhead Feeders
8.3	Point of Entry
8.4	Termination Cubicle
8.5	Final Splice
8.6	Company Feeder Extension
8.7	Required Testing
9.0	<b><u>REVENUE METERING</u></b>
9.1	Radial and Parallel Installations
9.2	Space for Meters
9.3	Wiring and Connections
10.0	<b><u>STANDARDS AND CODE REQUIREMENTS</u></b>
11.0	<b><u>DOCUMENTATION</u></b>
11.1	Required Submittals
11.2	Required Customer Information
11.3	Load Data
11.4	System Operation
11.5	Vendor Data
11.6	Design Changes
11.7	Tests
11.8	Number of Copies

---

<b>Specification</b>	<b>Revision</b>	<b>Rev Date</b>	<b>Effective Date</b>	<b>Copyright Information</b>	<b>Page</b>
EO – 2022	15		12/31/2009	1966-2009 Consolidated Edison Co. of New York, Inc.	4 / 81
<b>Filing Information</b>		Application and Design		Manual No. 4	

Paper copies of procedures and instructions are uncontrolled and therefore may be outdated. Please consult Distribution Engineering Intranet Site [Distribution Engineering](#) or <http://distribution>, for the current version prior to use.

## TABLE OF CONTENTS

<u>Paragraph</u>	<u>Description</u>
12.0	<u>MAINTENANCE AND INSPECTION</u>
13.0	<u>LIST OF REFERENCES</u>
14.0	<u>ATTACHMENTS</u>
15.0	<u>SPECIFICATION ACCEPTANCE</u>

---

<b>Specification</b>	<b>Revision</b>	<b>Rev Date</b>	<b>Effective Date</b>	<b>Copyright Information</b>	<b>Page</b>
EO – 2022	15		12/31/2009	1966-2009 Consolidated Edison Co. of New York, Inc.	5/81
<b>Filing Information</b>		Application and Design		Manual No. 4	

Paper copies of procedures and instructions are uncontrolled and therefore may be outdated. Please consult Distribution Engineering Intranet Site [Distribution Engineering](#) or <http://distribution>, for the current version prior to use.

## **GENERAL SPECIFICATION FOR HIGH TENSION SERVICE**

### 1.0 **PURPOSE**

The purpose of the **General Specification** is to provide the Consolidated Edison Company's general requirements for High Tension service and to outline the various types of High Tension Services available. The General Specification details the areas of responsibility for ownership, construction, alteration, operation and maintenance of equipment. The Company's detailed engineering requirements for the High Tension Service are given in the supplemental **Technical Specification**. The **General** and the **Technical Specifications**, with the appropriate support documents, comprise the Company's requirements for the Customer to obtain High Tension service. To be considered for High Tension service, which is a non-standard service, the customer must agree to all of the requirements contained herein.

### 2.0 **APPLICATION**

All Energy Service Departments and High Tension Customers.

### 3.0 **DEFINITIONS**

- 3.1 **Customer and Company** - For future reference throughout this specification, the Consolidated Edison Company of New York, Inc. is referred to as the "Company". All reference to "Customer" shall refer to the owner of the installation as defined in the supplemental **Technical Specification**.
- 3.2 **Company Service Type and Voltage** - High Tension Service is either Radial or Parallel. All High Tension Service Customer's are provided a primary nominal voltage of; 4 kV, 13 kV, 27 kV or 33 kV. The Con Edison Customer Service Representative will provide the actual service voltage on request. Billing will be at the appropriate High Tension rate in accordance with the provisions of the **Schedule for Electricity and the Requirements for Electric Service Installations** or other contract agreements. In all cases, the Customer provides primary switchgear and power transformers to isolate the Customer's service from the Company system.

Specification	Revision	Rev Date	Effective Date	Copyright Information	Page
EO – 2022	15		12/31/2009	1966-2009 Consolidated Edison Co. of New York, Inc.	6 / 81
<b>Filing Information</b>		Application and Design		Manual No. 4	

Paper copies of procedures and instructions are uncontrolled and therefore may be outdated. Please consult Distribution Engineering Intranet Site [Distribution Engineering](#) or <http://distribution>, for the current version prior to use.

The Customer's utilization voltage is developed on the load side of the Customer owned power transformers. If the utilization voltage is the same as the supplied voltage, then 1:1 isolation power transformers will be required.

- 3.3 **Customer Utilization Voltage** - The Customer's utilization voltage is based on the Customer's equipment requirements. The Customer's responsibility is to install equipment that will properly operate within the range of standard voltage deviations. The Customer's responsibility includes the installation of protective devices that will protect against transient voltage excursions, harmonics, momentary voltage sags, and unbalances.
  
- 3.4 **Contingencies** - Each part of the Company's service territory has been categorized by the number of allowable coincidental feeder outages that can be tolerated without adversely affecting the character of the Customer's service. These outages are referred to as **contingencies**. In a **first contingency area**, the Customer's installation must be designed for the loss of one primary service feeder. In a **second contingency area**, the Customer's installation must be designed for the loss of two primary service feeders. Therefore, to ensure the Customer's service configuration matches the Company's design criteria, the Customer is provided a minimum of two primary service feeders in a first contingency area and a minimum of three primary service feeders in a second contingency area. During contingency operation, the design (capacity, configuration, relays, transformers, switchgear, etc.) of the customer's installation must be such that the Customer's entire maximum demand can be supplied without overloading his equipment remaining on line in accordance with the electrical codes governing the use of his equipment.
  
- 3.5 **Feeder Bands** - A "Feeder Band" is defined, in both first and second contingency design areas, as two network feeders identified as primary service feeders supplying the customer's high tension service that are installed in a common duct bank, utility pole or equipment room. The term feeder band is also applied to the customer's primary feeder switchgear lineup (e.g., two primary feeder switchgear lineups housed in one electrical equipment room).
  
- 3.6 **Primary Service Feeder Switchgear Lineup** - The Customer's high tension equipment including the pothead compartment, revenue service metering compartments and Primary Service Feeder circuit breaker associated with and interconnected to a Company Primary Service Feeder.

Specification	Revision	Rev Date	Effective Date	Copyright Information	Page
EO – 2022	15		12/31/2009	1966-2009 Consolidated Edison Co. of New York, Inc.	7 / 81
<b>Filing Information</b>		Application and Design		Manual No. 4	

Paper copies of procedures and instructions are uncontrolled and therefore may be outdated. Please consult Distribution Engineering Intranet Site [Distribution Engineering](#) or <http://distribution>, for the current version prior to use.

- 3.7 **Electrical Equipment Rooms** - Electrical equipment rooms such as switchgear and transformer rooms, battery rooms, etc shall only be used to house electrical equipment/systems with the exception of the non-electrical equipment/systems that serve the electrical room (e.g., ductwork that provides ventilation for a transformer room).
- 3.8 **Switchgear** - Unless otherwise noted, all reference to primary switchgear equipment will be medium voltage metal-clad circuit breakers or metal enclosed fused load-break disconnect switches. However, due to the high fault currents on the Company's system, fused load-break disconnect switch applications are limited to the 4 kV supply system and for certain applications in the 13 kV areas in Staten Island and Westchester.
- 3.9 **Switchgear Room** - An electrical equipment room located in the customer's facility which houses the customer's primary distribution switchgear and associated electrical equipment.
- 3.10 **Transformer Room** – An electrical equipment room located in the Customer's facility dedicated to housing their dry-type power transformer.
- 3.11 **Transformer Vault** – An unattended isolated enclosure or structure housing the customer's liquid-filled power transformer.

4.0 **GENERAL**

- 4.1 **Customer Data** - Based on the Customer's submitted data, the Company will review its facilities and recommend the type of service which can be installed. Where a choice is given, the Customer shall select one of the alternatives provided by the Company. The Company's decision on the number of supply feeders will be based on the Customer's load requirement, contingency category, supply feeder availability, feeder loading and other pertinent factors. The Customer shall review the Company's EO-2022 **General and Technical Specification** requirements to assist in the design of the High Tension service. The Customer shall advise the Company of any anticipated Customer load changes so that the Company can reevaluate the adequacy of its distribution supply system and Customer's primary service feeder cables. If and when the customer's load increases, then the customer must reevaluate the capacity of his equipment to insure that it can operate within the limits specified in the governing electrical codes during both normal and the specified contingency conditions for the location.

Specification	Revision	Rev Date	Effective Date	Copyright Information	Page
EO – 2022	15		12/31/2009	1966-2009 Consolidated Edison Co. of New York, Inc.	8 / 81
<b>Filing Information</b>		Application and Design		Manual No. 4	

Paper copies of procedures and instructions are uncontrolled and therefore may be outdated. Please consult Distribution Engineering Intranet Site [Distribution Engineering](#) or <http://distribution>, for the current version prior to use.



4.2 **General & Technical Specifications** - Upon finalizing the selection of the High Tension service design, the Company will prepare a site specific **Technical Specification** (with a DE reference number) and support document(s). The **General Specification** and the site specific **Technical Specification** shall be used by the Customer in the design of the High Tension service installation. It is highly recommended that the Customer incorporates the latest revision of the entire EO-2022 specification in his bid, purchasing and design specification packages. When the **Technical Specification** is finalized it shall be signed by the Customer and Company's representatives.

4.3 **Service Availability** - Recommendations and requirements outlined in the Company specifications and/or project documents shall apply to the specific location and load. At other locations or for other load requirements, a service with similar characteristics may not be available and different requirements may be imposed.

5.0 **RADIAL DESIGN CONFIGURATION** - (See Figures 1 & 2)

5.1 **Radial Design** - The Radial type design is permitted for installations located in first contingency design areas. A Radial type Customer accepts primary service feeders at a Customer owned property line manhole and terminates the primary service feeders at a Customer owned primary service feeder disconnecting device. This type of Customer can tolerate a feeder outage during loss of a primary service feeder, interruption during transfer, autotransfer or a Customer component failure (e.g., power transformer, primary service feeder breaker, etc.). The outage duration will be a function of the time to repair or replace the failed component or the time the Company requires to restore the service.

5.2 **Relay Protection** - The Customer shall meet the Company's relay protection requirements which protect the Company's distribution system and the Customer's facility. The Customer shall install and maintain necessary equipment to:

- Automatically trip the primary service feeder circuit breaker if the current and voltage deviates to an extent that would affect the Customer's operating system or the Company's distribution system.
- Prevent energizing a de-energized Company primary service feeder.

Specification	Revision	Rev Date	Effective Date	Copyright Information	Page
EO – 2022	15		12/31/2009	1966-2009 Consolidated Edison Co. of New York, Inc.	9 / 81
<b>Filing Information</b>		Application and Design		Manual No. 4	

Paper copies of procedures and instructions are uncontrolled and therefore may be outdated. Please consult Distribution Engineering Intranet Site [Distribution Engineering](#) or <http://distribution>, for the current version prior to use.

- Coordinate with Company relay devices and to isolate all Customer faults on the Customer premises.

Protective relay requirements are detailed in the Technical Specification.

- 5.3 **Manual and Automatic Load Shifting** - Manual load shifting of Customer's secondary bus loads from one primary service feeder to an alternate source of power supply, will not be permitted without prior Company approval. Automatic load transfer, of emergency load buses will be permitted for a loss of either primary service feeder or Customer equipment failure. These loads and the mode of transfer shall be defined in a Customer's **System Operation Specification** that is submitted to the Company. All load transfers shall be made through an approved **break before make** transfer type system.
- 5.4 **Automatic Transfer Eligibility** - The Radial design allows for an automatic transfer of Customer load for a primary service feeder or component failure. This automatic transfer option is reserved for Customers with CRITICAL loads only (e.g., hospitals, public service installations, correctional facilities, etc.).
- 5.5 **Automatic Transfer Logic** - The Customer shall provide protective relay devices in the automatic transfer circuitry to inhibit a transfer of a faulted portion of the Customer's system to an alternate source. The controls shall incorporate a **manually reset lockout relay** (see the **Technical Specification** for other engineering requirements).
- 5.6 **Automatic Transfer Time Delay** - Automatic transfer control shall include a timer to prevent load transfer under transient system conditions.
- 5.7 **Transfer of Customer Load Buses** - Automatic and manual transfer of Customer load buses shall be arranged on a **break before make** basis to negate Customer paralleling of the primary service feeders. The Customer shall provide a paralleling bypass key, which will be under the Company's jurisdiction, for transfer of load during scheduled work and the return to normal supply.
- 5.8 **Manual Transfer and Retransfer** - Manual load transfer and retransfer of buses through normally open bus tie switchgear is made under the jurisdiction of the Company's District

Specification	Revision	Rev Date	Effective Date	Copyright Information	Page
EO – 2022	15		12/31/2009	1966-2009 Consolidated Edison Co. of New York, Inc.	10 / 81
<b>Filing Information</b>		Application and Design		Manual No. 4	

Paper copies of procedures and instructions are uncontrolled and therefore may be outdated. Please consult Distribution Engineering Intranet Site [Distribution Engineering](#) or <http://distribution>, for the current version prior to use.

Operator. Transfer of loads in excess of those already defined in the Customer's Operating Specification must be approved by the Company prior to the transfer. All Customer internal failures shall be repaired and tested satisfactorily prior to the return to service. The Customer's load shall be transferred back to its normal supply as soon as possible.

- 5.9 **Interlocking System Electrical Controls** - Customer's who have been given permission to use remote control electrical interlock systems shall have the interlock contacts monitored at a manned control room. The alarms shall indicate any primary service feeder status change or circuit transfer. The Customer shall maintain qualified operating personnel on a 24 hour, 7 day a week basis to report all alarms to the Company's District Operator. The notification shall be made within one hour of the alarm and the Customer's operating personnel shall await the Company's District Operators instructions. To properly expedite the isolation and grounding of the primary service feeder, the one hour maximum response time must be adhered to on a 24 hour, 7 day a week basis. For delays beyond the Customer's control, the Customer must use his best effort to respond to Company switching instructions as quickly as possible. If in the Company's opinion, the Customer's response time is not appropriate, the right to use electrical interlocks will be withdrawn and mechanical interlocks will be required.
- 5.10 **Grounding** - The Customer shall provide and install a ground mat and loop system for substation equipment grounding. The grounding system shall be designed as per industry standards to be capable of carrying the available fault currents and to limit voltage gradients in the substation to within acceptable step and touch potentials. The Customer shall also provide and install acceptable equipment for grounding each primary service feeder at the line side of the primary disconnecting device. In addition to the approved methods of grounding addressed in this specification, the Customer shall also provide OSHA approved ground studs on the line side of each disconnecting device and associated ground cables and hotstick.
- 5.11 **G&T Device and Ground Switch** - The Company requires the Customer to provide a means for grounding each of the Company's primary service feeders. When drawout type circuit breakers are used, a Ground and Test (G&T) device or a ground switch may be used for grounding the primary service feeders. When a fused load-break disconnect switch is used as the primary service feeder disconnect, a ground switch is required for each primary service feeder. The ground switch shall be located on the line side of the first disconnect device and shall be key interlocked with its associated primary service feeder disconnect device to ensure the primary service feeder disconnect device is locked open prior to closing the ground switch. The ground switch shall be inhibited from closing if voltage is present on the primary service

Specification	Revision	Rev Date	Effective Date	Copyright Information	Page
EO – 2022	15		12/31/2009	1966-2009 Consolidated Edison Co. of New York, Inc.	11 / 81
<b>Filing Information</b>		Application and Design		Manual No. 4	

Paper copies of procedures and instructions are uncontrolled and therefore may be outdated. Please consult Distribution Engineering Intranet Site [Distribution Engineering](#) or <http://distribution>, for the current version prior to use.

feeder. Interlocks shall also ensure the ground switch is locked open before the primary service feeder disconnect can be closed. The ground and primary service feeder disconnect devices shall be able to be in the open position simultaneously.

- 5.12 **Emergency Generators** - Customer's emergency generator(s) shall not be connected in parallel with the Company's service either at the primary or secondary voltage levels. In addition, service takeoffs serving Customer switchboards shall not be paralleled. Where the Customer switchboards require a backup source, a Company approved **break before make** type Automatic Transfer Switch or suitable key interlocked circuit breakers shall be used. Under certain circumstances closed transition transfer of emergency generators will be considered as per Con Edison Specification EO-2134, Closed Transition Transfer From and To Con Edison's Supply.
- 5.13 **Remote Monitoring and Control** - The Company reserves the right to install, at any time, remote monitoring and control equipment on the Customer's primary service feeder switchgear.

6.0 **PARALLEL DESIGN CONFIGURATION** - (See Figure 3)

- 6.1 **Parallel Design** - Parallel type design will be permitted for installations located in second contingency design areas. Parallel type design may be permitted for installations located in a first contingency design area depending on the configuration of the primary service feeders. Consult with the Company to determine if parallel type design is permitted in a first contingency design area. Paralleling of the primary service feeders will **only** be permitted on the secondary side of the Customer's power transformers. Circuit breakers are required as the primary service feeder and transformer main disconnect devices. The secondary connections of the Customer's power transformer shall be connected in parallel through normally closed transformer secondary main and bus tie circuit breakers. Paralleling on the primary service feeders is **not** permitted.
- 6.2 **Relay Protection** - Relay protection shall be employed to protect the Company's system and the Customer's facility. The Company will comment on the Customer's relaying designs up to and including the Customer's load bus and load takeoff circuits. In addition to the requirements found in paragraph 5.2, reverse power and directional overcurrent relays shall be provided for each primary service feeder. Fault detection for backfeed into a phase to ground fault shall be provided by either a zero sequence overvoltage relay connected to broken delta VT's or an over/under voltage relay connected to a phase to ground VT. Backup protection shall also be

Specification	Revision	Rev Date	Effective Date	Copyright Information	Page
EO – 2022	15		12/31/2009	1966-2009 Consolidated Edison Co. of New York, Inc.	12 / 81
<b>Filing Information</b>		Application and Design		Manual No. 4	

Paper copies of procedures and instructions are uncontrolled and therefore may be outdated. Please consult Distribution Engineering Intranet Site [Distribution Engineering](#) or <http://distribution>, for the current version prior to use.

required (see the Technical Specification for additional relay protection requirements). All protective relays that operate for faults in the Customer's equipment shall open the associated disconnect device via a manually reset lockout relay. Remotely alarmed trip circuit monitoring relays are required for the main power transformer primary and secondary circuit breakers, bus tie circuit breakers and the associated lockout relays that trip these circuit breakers. Monitoring relays shall be connected to the end of the trip ladder so that trip contact wiring will be monitored.

6.3 **Grounding** - See paragraphs 5.10 and 5.11.

6.4 **Emergency Generators** - See paragraph 5.12.

6.5 **Remote Monitoring and Control** - See paragraph 5.13.

## 7.0 **SERVICE VAULTS AND COMPARTMENTS**

7.1 **Items for Review** - Customer shall furnish all electrical and site drawings, diagrams, specifications and Bill of Materials required to evaluate the complete electrical service installation. This shall include, but not limited to; manholes, feeder cables, splices, circuit breakers, fused load-break switches, power and instrument transformers, disconnects, ground and transfer switches, buses, power transformer vaults and oil containment systems, relays and associated devices, fuses, batteries and battery chargers, etc.

7.2 **Electrical Equipment Rooms** - Electrical equipment rooms such as switchgear and transformer rooms, vaults, battery rooms, etc shall only be used to house electrical equipment/systems with the exception of the non-electrical equipment/systems that serve the electrical room (e.g., ductwork that provides ventilation for a transformer room). Equipment and/or systems that serve other purposes shall not be located within or be allowed to pass through these spaces. This includes ductwork, hydronic heating/cooling piping, plumbing systems, roof drainage systems, etc. Electrical equipment rooms shall be adequate in size and layout such that all electrical equipment components such as transformers and medium voltage switchgear can be conveniently accessed for inspection and/or maintenance and can be conveniently removed for repair or replacement. All clearances required by the code and recommended by equipment manufacturers shall be provided. Each electrical equipment room shall be accessible from an egress corridor and, where appropriate, from the exterior of the building as well. Access to equipment rooms shall not be provided through other spaces such as restrooms, offices, etc. It

Specification	Revision	Rev Date	Effective Date	Copyright Information	Page
EO – 2022	15		12/31/2009	1966-2009 Consolidated Edison Co. of New York, Inc.	13 / 81
<b>Filing Information</b>		Application and Design		Manual No. 4	

Paper copies of procedures and instructions are uncontrolled and therefore may be outdated. Please consult Distribution Engineering Intranet Site [Distribution Engineering](#) or <http://distribution>, for the current version prior to use.

shall not be necessary to travel through a vulnerable finished area or a functioning occupied area in order to reach an equipment room. Electrical equipment room doors shall open outward and shall be equipped with locks and accessible only to qualified personnel. Doors shall be equipped with a quick release mechanism with a full width actuator (i.e., panic bar) on the inside of the door and shall be capable of opening the door from the inside even if locked. Customer transformer vaults, transformer rooms, equipment and switchgear equipment areas shall be free of debris and shall incorporate Company safety design standards.

7.2.1 Two primary feeder service switchgear line-ups may be housed in one electrical equipment room provided the spacing between the primary feeder service switchgear lineups is at least ten (10) feet.

### 7.3 Power Transformers –

#### 7.3.1 Liquid filled power transformers –

7.3.1.1 Liquid-filled power transformers are permitted for all voltage levels. Oil type power transformers are limited to outdoor installations. Non-flammable liquid-filled power transformers may be installed indoors.

7.3.1.2 The Customer shall provide Fire/Blast walls for all liquid-filled transformer installations between outdoor liquid-filled power transformers and adjacent power transformers, equipment or building structures, as per code.

#### 7.3.2 Dry-Type Power Transformers –

7.3.2.1 Company approved dry type power transformers, will be permitted as primary service feeder power transformers for indoor installations. Company approved dry type transformers shall have primary and secondary coils vacuum cast in epoxy resin, utilizing step-lap mitered cruciform core construction. Customers choosing to use dry type power transformers shall submit the appropriate documentation to the Company for approval.

7.3.2.2 No more than two dry type power transformers shall be installed in one transformer room. Transformer rooms housing dry type transformers shall be constructed of concrete block or reinforced concrete two (2) hour fire rated walls.

Specification	Revision	Rev Date	Effective Date	Copyright Information	Page
EO – 2022	15		12/31/2009	1966-2009 Consolidated Edison Co. of New York, Inc.	14/81
<b>Filing Information</b>		Application and Design		Manual No. 4	

Paper copies of procedures and instructions are uncontrolled and therefore may be outdated. Please consult Distribution Engineering Intranet Site [Distribution Engineering](#) or <http://distribution>, for the current version prior to use.

For transformer rooms where the distance between transformers or between transformers and any associated electrical equipment is less than ten (10) feet, firewalls shall be required between the dry type power transformers and between the transformers and such adjacent equipment.

7.3.2.3 All power transformers shall comply with the BIL ratings listed in this specification. Note: Equipment BIL ratings shall be without the use of surge arresters.

7.4 **Environmental Issues**

7.4.1 **Power Transformer Oil Containment** - Liquid filled power transformers require an oil containment system in event of a spill or a leak. An approved oil containment system (e.g. catch basin) and an approved drainage method shall be employed to prevent oil spillage into a waterway, sewer system or the ground. The Company will review the Customer’s design to determine whether the Customer’s system is in compliance with the Company’s environmental requirements.

7.5 **Security Fence and Lighting** - Security fencing and lighting shall be provided for outdoor switchgear, power transformers and electrical equipment.

8.0 **PRIMARY SERVICE FEEDERS**

8.1 **Underground Feeders** - For Customers supplied via underground feeders, the Company will supply and install primary service feeder cables up to the Customer’s approved property line manhole. The property line manhole is provided and installed by the Customer and is conveniently located at the Customer's property line. A separate property line manhole is required for every two primary supply feeders.

8.2 **Overhead Feeders** - For Customers supplied via overhead feeders, the Company shall install overhead cable or conductors to the first point of attachment on or near the front of the building, or the first Customer owned supporting structure near the property line located adjacent to a public street.

8.3 **Point of Entry** - The Company will choose the point of entry (P.O.E.) and the Customer shall provide and install primary service feeder cables, conduits, and duct banks (if required by codes)

Specification	Revision	Rev Date	Effective Date	Copyright Information	Page
EO – 2022	15		12/31/2009	1966-2009 Consolidated Edison Co. of New York, Inc.	15 / 81
<b>Filing Information</b>		Application and Design		Manual No. 4	

Paper copies of procedures and instructions are uncontrolled and therefore may be outdated. Please consult Distribution Engineering Intranet Site [Distribution Engineering](#) or <http://distribution>, for the current version prior to use.

from the Customer's service equipment to the Customer's property line manhole or overhead structure at the P.O.E.

- 8.4 **Termination Cubicle** - The primary service feeders shall terminate within an approved pothead (Termination) compartment. The pothead, and its compartment shall be provided and installed by the Customer. All primary service feeder terminations are provided by the Customer and approved by the Company.
- 8.5 **Final Splice** - The Company will make the required splice between the Company's and the Customer's primary service feeder cables in the property line manhole. The Customer shall furnish splice kits (and spare splice kits shall be available at the site) if the portion of the primary service feeder cable cannot be spliced using a standard Company splice kit.
- 8.6 **Company Feeder Extension** - The Company may extend the primary service cable to the Customer's service equipment if, in the Company's analysis, the cost to the Company of extending the service cables to the Customer's termination cubicles will not be more than terminating the cables at a property line manhole and the service cables can be installed in one continuous pull from the street.
- 8.7 **Required Testing**
  - 8.7.1 Prior to energization, the Customer shall allow the Company to perform all required tests on the combined Company/Customer primary service feeder cables and Customer terminations in conformance with the latest revision of Company Specification EO-4019.
  - 8.7.2 Prior to energization the Customer shall also perform a service equipment **Acceptance Test** and submit the results to the Company for review and approval.
  - 8.7.3 Prior to energization, the customer shall also be required to perform the certified relay testing and submit their results to the Company for review and approval.
  - 8.7.4 All required Customer testing shall be performed by firms certified by InterNational Electrical Testing Association (NETA) to perform the testing.

## 9.0 **REVENUE METERING**

Specification	Revision	Rev Date	Effective Date	Copyright Information	Page
EO – 2022	15		12/31/2009	1966-2009 Consolidated Edison Co. of New York, Inc.	16 / 81
<b>Filing Information</b>		Application and Design		Manual No. 4	

Paper copies of procedures and instructions are uncontrolled and therefore may be outdated. Please consult Distribution Engineering Intranet Site [Distribution Engineering](#) or <http://distribution>, for the current version prior to use.



- 9.1 **Radial or Parallel Installations** - Radial or Parallel design installations shall be metered on the line side of the primary service feeder disconnect devices. The Customer shall provide and install a metering cubicle for each primary service feeder. The Customer shall also install and wire the Company furnished revenue metering instrument transformers as per Company Specification MES 350 and Company provided detailed metering specifications and requirements.
- 9.2 **Space for Meters** - The Customer shall provide a convenient location with suitable space, for installation and connection, of Company furnished meters and revenue meter devices (Instrument transformers, Watt-hour, Demand Meter, Totalizer, etc.) within 25 foot of the revenue metering instrument transformers.
- 9.3 **Wiring and Connections** - The Customer shall furnish, install and maintain all mounting facilities, wiring and conduit for connection of the revenue metering instrument transformers to the metering devices for the initial installation and any subsequent alterations. Final connection to the meters from the associated instrument transformers will be made by the Company. The Customer shall make the primary connection to the metering instrument transformers. The Customer shall allow Company access for meter reading, testing and maintenance without prior notification.

10.0 **STANDARD AND CODE REQUIREMENTS**

Unless otherwise noted herein, all equipment furnished and installed by the Customer, shall be in accordance with the latest (and most stringent) IEEE (ANSI), NEMA, National Electric Code (NEC), City Administration Code, DEP, EPA, OSHA and all applicable local codes and standards.

11.0 **DOCUMENTATION**

- 11.1 **Required Customer Information** - Prior to the issuance of the Technical Specification, the Customer shall submit the proposed One Line diagram(s) incorporating any existing High Tension design. The One Line diagram(s) shall be accompanied by the proposed connected and demand load data summary, load cycle profile, service description, and a preliminary short circuit and relay coordination study for Company's conceptual approval.
- 11.2. **Load Data** - The load data summary shall consist of a listing of all the connected and demand loads, in terms of the rated values and anticipated operating loads and standby elements. Based on the modes of operation of the Customer's loads, the Customer shall submit a

Specification	Revision	Rev Date	Effective Date	Copyright Information	Page
EO – 2022	15		12/31/2009	1966-2009 Consolidated Edison Co. of New York, Inc.	17/81
<b>Filing Information</b>		Application and Design		Manual No. 4	

Paper copies of procedures and instructions are uncontrolled and therefore may be outdated. Please consult Distribution Engineering Intranet Site [Distribution Engineering](#) or <http://distribution>, for the current version prior to use.

preliminary daily load cycle profile. Motor load data must include the normal load level and power factor, in addition to the inrush current. The electrical starting characteristics of all high inrush current equipment shall be submitted in advance of any purchase.

- 11.3. **Customer’s System Operations Specification** - The Customer shall produce a System Operating document which shall detail the normal and contingency modes of operation and define all primary service disconnect switch and circuit breaker operating positions. All switching modes of operation shall be fully detailed in this document which will be finalized as an approved Customer System Operating Specification. A list of Customer key personnel that the Company may contact in the event of an emergency, with their respective telephone numbers shall be included in the final version of the Customer’s System Operation Specification. The Customer’s System Operation Specification shall be updated as required and resubmitted to the Company.
- 11.4 **Customer Training** - The Customer shall provide training to ensure that their qualified personnel have the knowledge and skills required to safely operate and maintain the high tension electrical equipment. The Customer shall certify that employee training has been accomplished and is being kept up to date. The certification shall contain each employee's name and dates of training and the Customer shall produce this documentation on request by the Company.
- 11.5 **Vendor Data** - The Customer shall submit to the Company for approval, all vendor data concerning the primary service equipment including the equipment ratings and one line diagram. After vendor approval, the Customer shall submit; the final one line diagram, three line diagrams, control & protective relays schematics including the interlocks, equipment layout drawings and the bill of materials with catalog cuts as detailed site specific design specification.
- 11.6 **Design Changes** - During the design and construction of the project, any changes in either the loads, modes of operation, service equipment arrangement and/or interlock and protective relaying schemes from that of the approved conceptual design shall be submitted to the Company for approval and record. The Customer shall resubmit all the data as noted above with the proposed changes highlighted for the Company's approval prior to the manufacture of the service equipment.
- 11.7 **Testing** – After the completion of the installation, the Customer must perform all acceptance testing as well as operational tests and calibrations on the protective relays. The Customer shall

Specification	Revision	Rev Date	Effective Date	Copyright Information	Page
EO – 2022	15		12/31/2009	1966-2009 Consolidated Edison Co. of New York, Inc.	18 / 81
<b>Filing Information</b>		Application and Design		Manual No. 4	

Paper copies of procedures and instructions are uncontrolled and therefore may be outdated. Please consult Distribution Engineering Intranet Site [Distribution Engineering](#) or <http://distribution>, for the current version prior to use.

test the circuit breaker including the control, indication, alarm and trip circuits, any mechanical, key or electrical interlocks, switchgear and grounding devices. The Company representatives will be present for the above tests. A complete Acceptance Test report as well as the protective relay certification test report must be submitted to the Company for approval at least two weeks prior to energization.

11.8 **Number of Copies** - The customer shall transmit **five (5)** copies of each document with each submission as noted above.

## 12.0 **MAINTENANCE AND INSPECTION**

12.1 Customer Training - The Customer shall be responsible for insuring that their designated operating personnel are trained to safely operate and perform the necessary maintenance on their high tension equipment. The Customer shall provide training to ensure that their qualified personnel are have the knowledge and skills required to safely operate and maintain the high tension electrical equipment. The Customer shall certify that employee training has been accomplished and is being kept up to date. The certification shall contain each employee's name and dates of training and the Customer shall produce this documentation on request by the Company.

12.2 After energization, the Customer shall be responsible for performing routine maintenance and inspection programs of all service equipment, vaults and compartments as defined in Company Specification EO-4035.

The Customer is also required to maintain an operating log and record all relay device targets and primary service feeder disconnect device trip events.

The maintenance and inspection procedures and records as well as operator training and certification shall be subject to inspection by the Company.

## 13.0 **LIST OF REFERENCES**

A complete list of references are attached to this **Specification**.

Specification	Revision	Rev Date	Effective Date	Copyright Information	Page
EO – 2022	15		12/31/2009	1966-2009 Consolidated Edison Co. of New York, Inc.	19 / 81
<b>Filing Information</b>		Application and Design		Manual No. 4	

Paper copies of procedures and instructions are uncontrolled and therefore may be outdated. Please consult Distribution Engineering Intranet Site [Distribution Engineering](#) or <http://distribution>, for the current version prior to use.

## 14.0 ATTACHMENTS

FIGURE No.1 - RADIAL DESIGN

FIGURE No.2 - RADIAL DESIGN - REMOTE LOAD CENTERS

FIGURE No.3 - PARALLEL DESIGN

Elie A. Chebli (signature on file)

-----  
Elie A. Chebli  
Department Manager  
Network Systems  
Distribution Engineering

D. Sammon/M. A. Kevelson

REVISION NO. 15:	FILE:
<b>General</b> - added: 3.5 to 3.10, 7.2, changes: 5.10, 6.1, 7.3, 7.4, 8.7, 10.0, 11.4, 11.7, 12.1, 12.2	Application and Design
<b>Technical</b> – changed: 3.0, 4.0, 5.11, 6.0, 7.2	Manual No. 4

Specification	Revision	Rev Date	Effective Date	Copyright Information	Page
EO – 2022	15		12/31/2009	1966-2009 Consolidated Edison Co. of New York, Inc.	20/81
<b>Filing Information</b>		Application and Design		Manual No. 4	

Paper copies of procedures and instructions are uncontrolled and therefore may be outdated. Please consult Distribution Engineering Intranet Site [Distribution Engineering](#) or <http://distribution>, for the current version prior to use.

15.0 **SPECIFICATION ACCEPTANCE**

Customer Specification No. DE.....

Location of H.T. Service.....  
.....  
.....

CON EDISON ACKNOWLEDGMENT:

Delivery of Specification:        Date .....

Con Edison representative .....

Title .....

CUSTOMER ACKNOWLEDGMENT:

Receipt of Specification:        Date.....

Customer representative.....

Title .....

Specification	Revision	Rev Date	Effective Date	Copyright Information	Page
EO – 2022	15		12/31/2009	1966-2009 Consolidated Edison Co. of New York, Inc.	21 / 81
<b>Filing Information</b>		Application and Design		Manual No. 4	

Paper copies of procedures and instructions are uncontrolled and therefore may be outdated. Please consult Distribution Engineering Intranet Site [Distribution Engineering](#) or <http://distribution>, for the current version prior to use.

**FIGURE No.1**  
**RADIAL DESIGN**  
 COMPANY HIGH TENSION FEEDERS, MAXIMUM 4 FEEDERS

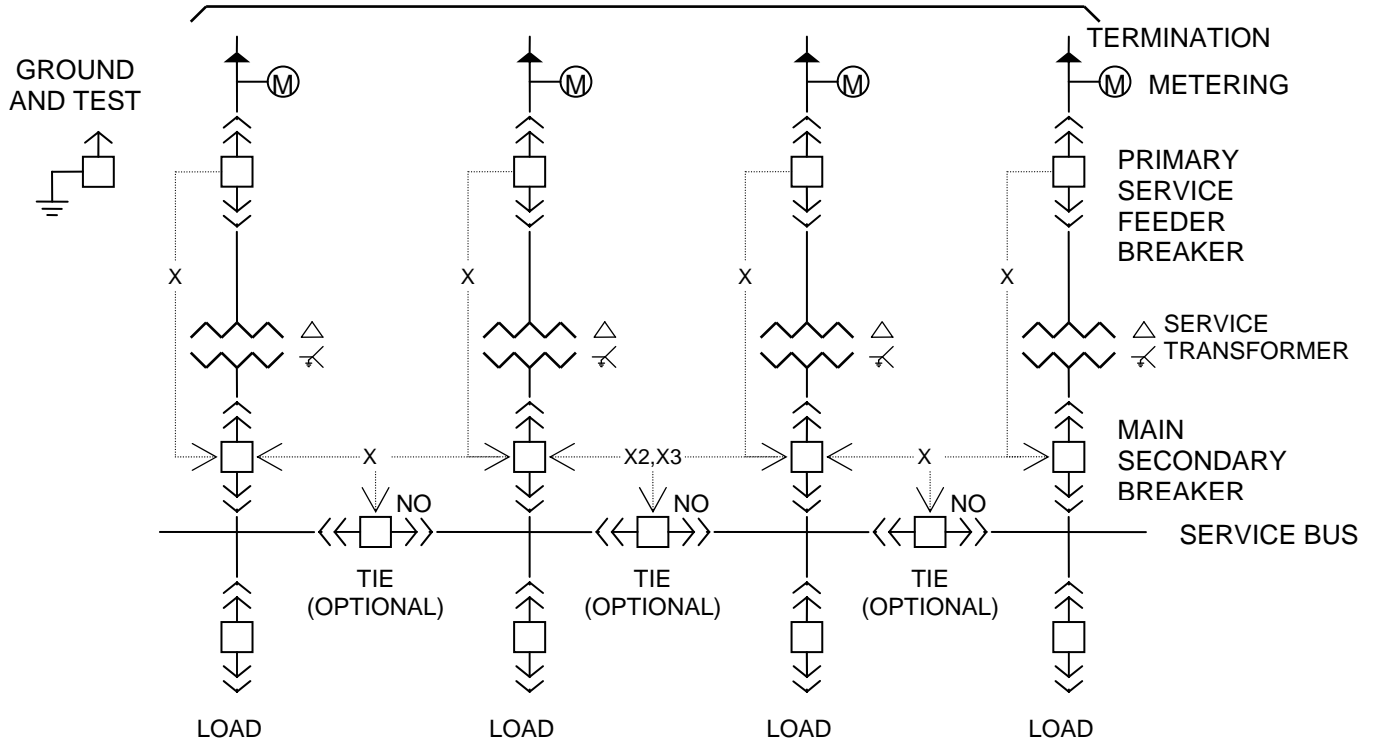

**NOTES:**

CUSTOMER DISTRIBUTION NOT SHOWN.

X1: BREAKER INTERLOCK, PRIMARY BREAKER SHALL BE CLOSED FIRST.

X2: BREAKER INTERLOCK, ONLY TWO CLOSED AT ONE TIME.

X3: BREAKER INTERLOCK, MANUAL OPERATION ONLY.

Specification	Revision	Rev Date	Effective Date	Copyright Information	Page
EO – 2022	15		12/31/2009	1966-2009 Consolidated Edison Co. of New York, Inc.	22/81
<b>Filing Information</b>		Application and Design		Manual No. 4	

Paper copies of procedures and instructions are uncontrolled and therefore may be outdated. Please consult Distribution Engineering Intranet Site [Distribution Engineering](#) or <http://distribution>, for the current version prior to use.

FIGURE No. 2  
RADIAL DESIGN - REMOTE LOAD CENTERS

COMPANY HIGH TENSION FEEDERS, MAXIMUM 4 FEEDERS

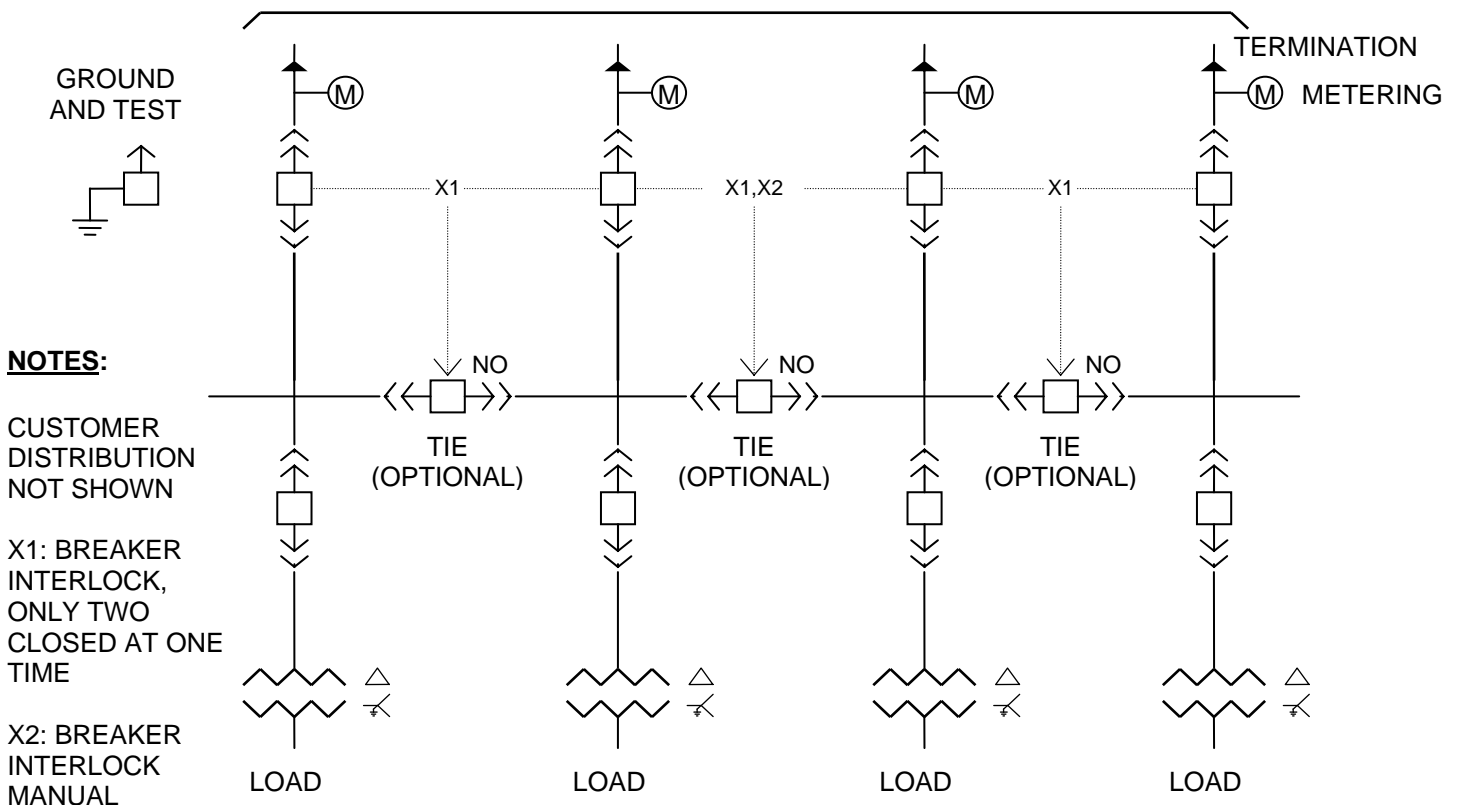

Specification	Revision	Rev Date	Effective Date	Copyright Information	Page
EO - 2022	15		12/31/2009	1966-2009 Consolidated Edison Co. of New York, Inc.	23/81
<b>Filing Information</b>		Application and Design		Manual No. 4	

Paper copies of procedures and instructions are uncontrolled and therefore may be outdated. Please consult Distribution Engineering Intranet Site [Distribution Engineering](#) or <http://distribution>, for the current version prior to use.

FIGURE No. 3  
**PARALLEL DESIGN**

COMPANY HIGH TENSION FEEDERS, 4 FEEDERS SHOWN, MAXIMUM 6 FEEDERS

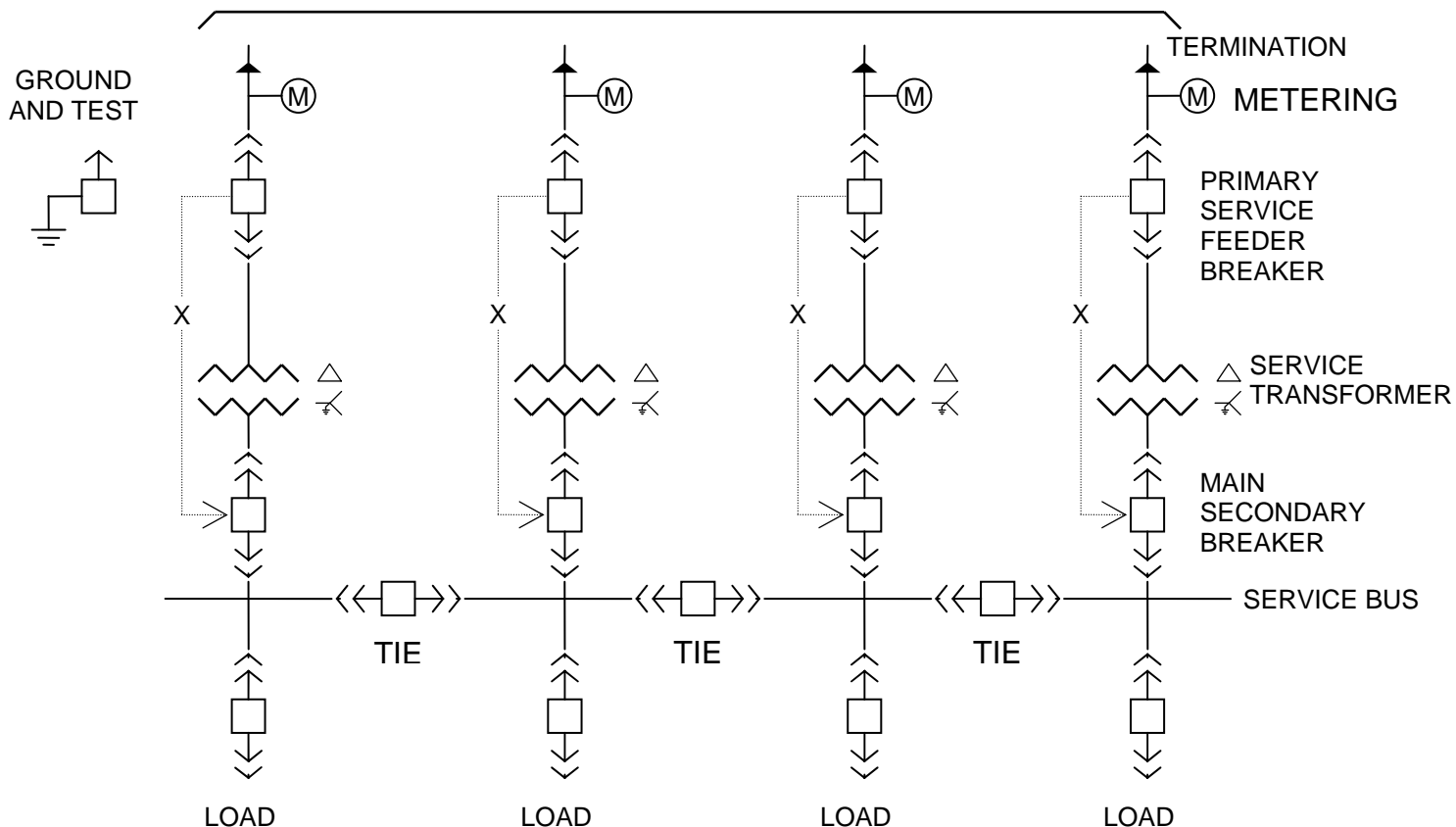

**NOTES:** CUSTOMER DISTRIBUTION NOT SHOWN.  
ALL BREAKERS ARE NORMALLY CLOSED.  
X: BREAKER INTERLOCK, PRIMARY BREAKER SHALL BE CLOSED FIRST.

Specification	Revision	Rev Date	Effective Date	Copyright Information	Page
EO - 2022	15		12/31/2009	1966-2009 Consolidated Edison Co. of New York, Inc.	24/81
<b>Filing Information</b>		Application and Design		Manual No. 4	

Paper copies of procedures and instructions are uncontrolled and therefore may be outdated. Please consult Distribution Engineering Intranet Site [Distribution Engineering](#) or <http://distribution>, for the current version prior to use.



**CONSOLIDATED EDISON COMPANY OF NEW YORK INC.  
4 IRVING PLACE  
NEW YORK, NY 10003**

**TEMPLATE for HIGH TENSION TECHNICAL SPECIFICATION FOR**

(enter the max. demand load at the facility and primary service voltage)

**3 PHASE, (...enter 3 or 4 here...) Wire, 60 HERTZ, SERVICE**

**FOR**

(...enter the Customer's name here...)

(...enter the Customer's address here...)

(...enter the Customer City, State and Zip Code here...)

(...street address of the service is entered here...)

(...enter Borough/County here...)

**SPECIFICATION NO.:** (enter DE.....)

**ISSUE DATE** (enter here)

**TABLE OF CONTENTS**

<b>Specification</b>	<b>Revision</b>	<b>Rev Date</b>	<b>Effective Date</b>	<b>Copyright Information</b>	<b>Page</b>
EO – 2022	15		12/31/2009	1966-2009 Consolidated Edison Co. of New York, Inc.	25 / 81
<b>Filing Information</b>		Application and Design		Manual No. 4	

Paper copies of procedures and instructions are uncontrolled and therefore may be outdated. Please consult Distribution Engineering Intranet Site [Distribution Engineering](#) or <http://distribution>, for the current version prior to use.

<b><u>Paragraph</u></b>	<b><u>Description</u></b>
1.0	<b><u>PURPOSE</u></b>
	1.1 Technical Specification
	1.2 Addendum Letter
2.0	<b><u>GENERAL INFORMATION</u></b>
3.0	<b><u>VAULTS, COMPARTMENTS &amp; EQUIPMENT ROOMS</u></b>
	3.1 Applicable Codes and Standards
	3.2 Physical Layout
	3.3 Level Floors
	3.4 Fencing, Lighting and Landscaping
	3.5 Substation Ground Loops
4.0	<b><u>ENVIROMENTAL ISSUES</u></b>
	4.1 Transformer Vault Drainage
5.0	<b><u>INCOMMING SUPPLY (PRIMARY SERVICE) FEEDERS</u></b>
	5.1 Overhead Feeders
	5.2 Underground Feeder Supply
	5.3 Customer Cables and Conductors
	5.4 Surge Protection
	5.5 Termination Cubicle
	5.6 Live Feeder Indicators
	5.7 Ground Studs and Grounding Cables
	5.8 Service Neutrals
	5.9 Bonding

## TABLE OF CONTENTS

Specification	Revision	Rev Date	Effective Date	Copyright Information	Page
EO – 2022	15		12/31/2009	1966-2009 Consolidated Edison Co. of New York, Inc.	26 / 81
<b>Filing Information</b>		Application and Design		Manual No. 4	

Paper copies of procedures and instructions are uncontrolled and therefore may be outdated. Please consult Distribution Engineering Intranet Site [Distribution Engineering](#) or <http://distribution>, for the current version prior to use.

## **Paragraph**

## **Description**

- 5.10 Corrosive Cable Environments
- 5.11 Feeder Separation
- 5.12 Underground Primary Service Feeder Conduit Installation
- 5.13 Conduit Sizing
- 5.14 Conduit Types
- 5.15 Spare Conduits
- 5.16 Property Line Manholes
- 5.17 Arcproofing

## 6.0

### **REVENUE METERING**

- 6.1 Mounting Facilities
- 6.2 Revenue Metering Instrument Transformers
- 6.3 Metering Cubicles
- 6.4 Phasing Receptacles
- 6.5 Customer's Equipment

## 7.0

### **SWITCHGEAR**

- 7.1 Applicable Standards
- 7.2 Switchgear Construction
- 7.3 Outdoor Switchgear
- 7.4 Outdoor Switchgear Doors
- 7.5 Indoor Switchgear Rooms
- 7.6 Switchgear Ratings
- 7.7 Switchgear Bus
- 7.8 Ground Bus
- 7.9 Grounding Devices
- 7.10 Cubicle Doors

## **TABLE OF CONTENTS**

<b>Specification</b>	<b>Revision</b>	<b>Rev Date</b>	<b>Effective Date</b>	<b>Copyright Information</b>	<b>Page</b>
EO – 2022	15		12/31/2009	1966-2009 Consolidated Edison Co. of New York, Inc.	27/81
<b>Filing Information</b>		Application and Design		Manual No. 4	

Paper copies of procedures and instructions are uncontrolled and therefore may be outdated. Please consult Distribution Engineering Intranet Site [Distribution Engineering](#) or <http://distribution>, for the current version prior to use.

## Paragraph

## Description

- 7.11 Barriers and Insulators
- 7.12 Shutters
- 7.13 Stop Blocks
- 7.14 Circuit Breaker Trip Interlocks
- 7.15 Fixed Type Circuit Breakers
- 7.16 Fused Loadbreak Disconnect Switches
- 7.17 Locking
- 7.18 Low Voltage Power Supply
- 7.19 Circuit Breaker Trip Controls
- 7.20 Circuit Breaker Control Switches
- 7.21 Maneuvering Switchgear

8.0

## MECHANICAL, ELECTRICAL, KEY INTERLOCKS AND AUTOMATIC TRANSFER

- 8.1 Key Codes
- 8.2 Fixed Type Circuit Breakers
- 8.3 Fused Disconnect Switch Cubicle Entry
- 8.4 Ground Switch Interlocks
- 8.5 Key Tagging and Key Storage Box
- 8.6 Multi-feeder Radial Installation Interlocks
- 8.7 Key Interlock Sequence
- 8.8 Electrical Interlocks
- 8.9 Remote Electrical Control Systems
- 8.10 Automatic Transfer
- 8.11 Automatic Transfer Function Guide
- 8.12 Manual Transfer - Interlocks and Relays
- 8.13 Programmable Logic Controller (PLC)

## TABLE OF CONTENTS

Specification	Revision	Rev Date	Effective Date	Copyright Information	Page
EO – 2022	15		12/31/2009	1966-2009 Consolidated Edison Co. of New York, Inc.	28 / 81
<b>Filing Information</b>		Application and Design		Manual No. 4	

Paper copies of procedures and instructions are uncontrolled and therefore may be outdated. Please consult Distribution Engineering Intranet Site [Distribution Engineering](#) or <http://distribution>, for the current version prior to use.

**Paragraph**

**Description**

9.0

**GROUNDING DEVICES**

9.1 GROUND & TEST (G&T) DEVICE

9.1.1 Function and Storage

9.1.2 Key Interlocking

9.1.3 Trip and Close Controls

9.1.4 Dual Function G&T Devices

9.1.5 Test Receptacles

9.1.6 Receptacle Shutters

9.1.7 Test Probes and Cables

9.1.8 G&T Device - Interlocking Requirements

9.2 GROUND SWITCHES

9.2.1 Function

9.2.2 Key Interlocking

9.2.3 Ground Switch Interlocking Requirements

9.2.4 Device Descriptions

9.2.5 Sequence 1 -To Apply Ground on the Utility Feeder

9.2.6 Sequence 2 - To Apply Ground on the Utility Feeder

9.2.7 Additional Requirements for Ground and Disconnect Switches

10.0

**SWITCHGEAR PROTECTION & CONTROL EQUIP'T**

10.1 Customer Requirements

10.2 Protective Relay Design

10.3 Voltage and Current Transformers

**TABLE OF CONTENTS**

**Paragraph**

**Description**

10.4 Voltage Transformer Accuracy Class

10.5 Current Transformer Accuracy Class

Specification	Revision	Rev Date	Effective Date	Copyright Information	Page
EO – 2022	15		12/31/2009	1966-2009 Consolidated Edison Co. of New York, Inc.	29/81
<b>Filing Information</b>		Application and Design		Manual No. 4	

Paper copies of procedures and instructions are uncontrolled and therefore may be outdated. Please consult Distribution Engineering Intranet Site [Distribution Engineering](#) or <http://distribution>, for the current version prior to use.

- 10.6 Current Transformer Short-Time Current Values
- 10.7 Ground Wiring Connection
- 10.8 Test Facilities
- 10.9 DC Power System

11.0 **POWER TRANSFORMERS**

- 11.1 Acceptable Power Transformers
- 11.2 Connections
- 11.3 BIL Requirements
- 11.4 Automatic Tap Changes

12.0 **EQUIPMENT AND FEEDER MARKINGS**

- 12.1 Nameplates and Labeling
- 12.2 Phase Markings
- 12.3 Terminal Blocks and Wire Markings

13.0 **PROOF TESTS**

- 13.1 Primary Service Feeder Cable, Bus, Potheads and Equipment
- 13.2 Customer Cable and Switchgear
- 13.3 Power Transformers

**TABLE OF CONTENTS**

**Paragraph**                      **Description**

14.0 **APPROVAL OF PROJECT DRAWINGS & DOCUMENTS**

Specification	Revision	Rev Date	Effective Date	Copyright Information	Page
EO – 2022	15		12/31/2009	1966-2009 Consolidated Edison Co. of New York, Inc.	30 / 81
<b>Filing Information</b>		Application and Design		Manual No. 4	

Paper copies of procedures and instructions are uncontrolled and therefore may be outdated. Please consult Distribution Engineering Intranet Site [Distribution Engineering](#) or <http://distribution>, for the current version prior to use.

- 14.1 Review Items: Initial Project Stage
- 14.2 Review Items: Design Stage
- 14.3 Review Items: Prior to Energization
- 14.4 Energization

15.0                    **LIST OF COMPANY REFERENCES**

16.0                    **CHECKLIST A**

17.0                    **CONTRACT ACCEPTANCE**

Specification	Revision	Rev Date	Effective Date	Copyright Information	Page
EO – 2022	15		12/31/2009	1966-2009 Consolidated Edison Co. of New York, Inc.	31 / 81
<b>Filing Information</b>		Application and Design		Manual No. 4	

Paper copies of procedures and instructions are uncontrolled and therefore may be outdated. Please consult Distribution Engineering Intranet Site [Distribution Engineering](#) or <http://distribution>, for the current version prior to use.

## 1.0 PURPOSE

- 1.1 **Technical Specification** - The purpose of the **Technical Specification** is to provide the Customer with a specification tailored to his installation and which adheres to the Con Edison Company's requirements. This specification, its support documents and the **General Specification**, shall be used by the Customer as the guide to design and install the high tension service. A high tension specification is required for a new Customer, for a change in the number of supply feeders, the type of operating system, or an upgrade of primary service equipment.
- 1.2 **Addendum Letter** - For an increase in Customer's load, changes in the number of bus load takeoffs or the addition of emergency generators, an **Addendum Letter** shall prepared by the Company and signed by the Customer. The Addendum Letter shall fully describe the change and shall be attached to the existing specification. The Addendum Letter is applicable for a load increase that does not affect the number of primary service supply feeders.

## 2.0 GENERAL INFORMATION

In this specification, the Consolidated Edison Company of New York, Inc. is referred to as the **Company**. All reference to the term **Customer** shall refer to as (enter the Customer's name.....).

Customer Service Engineering shall use this space to describe the specifics of the project, including:

- Present service configuration (if there is an existing service),
- Number of primary service feeders (initially and proposed for the future),
- Primary service voltage and power transformer secondary voltage
- Service configuration (parallel, radial, auto-transfer),
- The power transformer size (MVA or KVA) and the power transformer connection,
- Load demand (present, proposed and expected maximum),

Specification	Revision	Rev Date	Effective Date	Copyright Information	Page
EO – 2022	15		12/31/2009	1966-2009 Consolidated Edison Co. of New York, Inc.	32/81
<b>Filing Information</b>		Application and Design		Manual No. 4	

Paper copies of procedures and instructions are uncontrolled and therefore may be outdated. Please consult Distribution Engineering Intranet Site [Distribution Engineering](#) or <http://distribution>, for the current version prior to use.



- Number and size of the emergency generators (present and future) and where they are connected (example: on the 4 kV bus or 460V bus),
- Proposed service date,
- First or secondary design service and any special operating or design requirements,
- Service Classification.

### 3.0 **VAULTS, COMPARTMENTS AND EQUIPMENT ROOMS**

- 3.1 **Applicable Codes and Standards** - The design and construction of all vaults, compartments, equipment rooms and equipment shall be in accordance with the latest Company specifications, the IEEE standards C37 and C57, N.E.C., N.E.S.C., D.E.P., EPA, OSHA New York City and/or Westchester County or local building electrical, safety and environmental codes. Where a difference between codes and specifications exists, the more stringent requirement shall be employed.
- 3.2 **Physical Layout** - Power transformers and all primary service feeder and load bus equipment and cubicles shall be constructed with adequate space around each equipment item to ensure ease of equipment maintenance and removal. The equipment layout shall be such that no item will have to be removed to either maintain and/or remove another item of equipment. The Customer shall submit for review, a site plan with the physical layout of the primary service feeder, tie bus and load bus switchgear cubicles, the equipment switchgear room(s), switchgear yards and power transformer vaults.
- 3.3 **Level Floors** - Installations using drawout type switchgear shall have level floors and pads to ensure the circuit breakers, the Ground and Test (G&T) device or other test equipment, may be drawn easily in and out of a cubicle or moved between cubicles. In addition, all outdoor installations shall be designed with a minimum three-foot pad extension around the switchgear cubicle area to ensure ease of equipment and personnel movement.
- 3.4 **Fencing, Lighting and Landscaping** - The Customer shall provide security fencing and lighting to provide security for the outdoor switchgear, power transformers and other electrical equipment. Any additional perimeter fencing and landscaping needed to enclose the facility as required by the

Specification	Revision	Rev Date	Effective Date	Copyright Information	Page
EO – 2022	15		12/31/2009	1966-2009 Consolidated Edison Co. of New York, Inc.	33 / 81
<b>Filing Information</b>		Application and Design		Manual No. 4	

Paper copies of procedures and instructions are uncontrolled and therefore may be outdated. Please consult Distribution Engineering Intranet Site [Distribution Engineering](#) or <http://distribution>, for the current version prior to use.

municipalities must also be furnished, installed and maintained by the Customer.

3.5 **Substation Ground Loops** - The Customer shall install a ground mat and loop system for substation equipment grounding. The ground system shall be connected to each primary service feeder's ground conductor. The ground cable shall be a minimum 4/0 AWG bare copper conductor. Sufficient connections to the structural steel and the main metallic water pipe system shall be provided to ensure a maximum ground impedance of 10 ohms. Each primary and secondary switchgear ground bus, power transformer and metering cubicle shall be connected to the ground loop at two points at opposite ends of the equipment. Fencing for outdoor installations shall also be connected to the ground loop system at intervals no greater than 20 feet. All gates and doors shall be bonded to the ground loop system (NYCTA grounding procedures are detailed in Specification EO-2034).

4.0 **ENVIROMENTAL ISSUES**

4.1 **Transformer Vault and Drainage** - Each liquid filled power transformer shall occupy its own transformer vault. Pad mounted liquid filled power transformer vaults shall be designed with a containment system, which shall have sufficient capacity to contain 125% volume of the transformer's liquid in event of a leak. In addition, the transformer vault shall be equipped with an approved drainage system (e.g., sump pump equipped with either an oil sensor control which will disable the sump pump in the event of a transformer oil spill or an oil and water separator system). The proposed transformer vault drainage system shall be submitted to the Company for approval during the design stage of the project.

5.0 **INCOMIING SUPPLY (PRIMARY SERVICE ) FEEDERS**

5.1 **Overhead Feeders** - Customers supplied via overhead feeders shall furnish and install a Company approved support structure at or near the property line for connection to the Company's primary service feeder. The Customer shall supply the primary service conductors and make the connections from the property line structure to the Customer's primary service feeder switchgear.

Specification	Revision	Rev Date	Effective Date	Copyright Information	Page
EO – 2022	15		12/31/2009	1966-2009 Consolidated Edison Co. of New York, Inc.	34 / 81
<b>Filing Information</b>		Application and Design		Manual No. 4	

Paper copies of procedures and instructions are uncontrolled and therefore may be outdated. Please consult Distribution Engineering Intranet Site [Distribution Engineering](#) or <http://distribution>, for the current version prior to use.

- 5.2 **Underground Feeder Supply** - Customers supplied via an underground primary service feeder shall furnish and install a property line manhole(s) and a conduit system for the routing of the Company primary service feeder cables to the Customer's primary service feeder switchgear.
- 5.3 **Customer Cables and Conductors** - The Customer shall furnish and install Company approved primary service feeder cables or conductors from the property line overhead structure or underground manhole(s) to the Customer's primary service feeder termination cubicles. The switchgear termination connections shall be made by the Customer. Customer cables or conductors shall be compatible with the size, construction and ratings of the Company primary service feeder supply. Prior to the purchase of the cables or conductors, the Customer shall submit to the Company the specifications and details of installation and connection. Any deviation from the Company standards or approved vendors (list will be provided on request) must be approved by the Company prior to the cable or conductor purchase.
- 5.4 **Surge Protection** - The Customer may opt to install surge arresters on the load side of the primary service feeder disconnecting device for all services supplied by overhead primary service feeders. It is recommended that surge arrester sizing be in accordance with Company specification EO-2012.
- 5.5 **Termination Cubicle** - The Customer shall furnish and install a termination cubicle for each primary service feeder. The termination cubicle shall be sized to meet code requirements, and to ensure ease of access for maintenance of the primary service feeder potheads, phase and ground buses, and the **Live Feeder Indicators** as noted below.
- 5.6 **Live Feeder Indicators** - The Customer shall furnish and install **two neon glow tubes per phase** in each primary service feeder termination cubicle. The neon glow tubes shall be installed on the line side of any primary service feeder disconnecting device as detailed on Drawing EO-13079-C. Viewing windows of shatter proof material shall be provided in the cubicle door(s) to permit observation of the neon glow tubes by an operator.

Specification	Revision	Rev Date	Effective Date	Copyright Information	Page
EO – 2022	15		12/31/2009	1966-2009 Consolidated Edison Co. of New York, Inc.	35 / 81
<b>Filing Information</b>		Application and Design		Manual No. 4	

Paper copies of procedures and instructions are uncontrolled and therefore may be outdated. Please consult Distribution Engineering Intranet Site [Distribution Engineering](#) or <http://distribution>, for the current version prior to use.

5.7 **Ground Studs and Grounding Cables** - The Customer shall install OSHA approved type "Ball and Socket" designed **ground studs** (AB Chance C600-2102 or equivalent) on each bus phase in each primary service feeder termination cubicle. A ground stud shall be installed on the ground bus extended outside the cubicle to permit connection of portable ground cables. The ground studs shall be capped when not in use. The ground stud cap shall be so constructed for easy removal with a shotgun type of "hotstick." The Customer shall also provide one set of 4/0 AW, 600 Volt insulated, EPR **portable ground cables** with the appropriate grounding clamps (AB Chance C600-2101 or equivalent) installed. The grounding cables shall be approximately 10 foot in length and shall have a threaded grounding ferrule installed on each end. One end of the three phase cables shall have a ground clamp installed and the other end shall be joined together at a three way grounding terminal block (AB Chance PW600-0697 or equivalent) and a socket type grounding clamp. If the Customer has more than four primary service feeders a second set of portable ground cables shall be provided. The ground cables shall be hotstick operable and shall be stored at the project site in a cabinet under Company jurisdiction.

5.8 **Service Neutrals** - Each primary service feeder shall be furnished with a service conductor neutral. The service conductor neutral shall be copper cable with a minimum size as noted below. The Customer shall furnish, install and connect the service conductor neutral to a ground bus within the termination cubicle.

Conductor Size/Phase	Minimum Neutral Size
500 MCM	4/0 AWG
350 MCM	4/0 AWG
4/0 AWG	4/0 AWG
2/0 AWG	2/0 AWG

5.9 **Bonding** - Feeder cables with metallic sheaths shall have their sheaths bonded together and shall be connected to their associated termination cubicle ground bus.

Specification	Revision	Rev Date	Effective Date	Copyright Information	Page
EO – 2022	15		12/31/2009	1966-2009 Consolidated Edison Co. of New York, Inc.	36 / 81
<b>Filing Information</b>		Application and Design		Manual No. 4	

Paper copies of procedures and instructions are uncontrolled and therefore may be outdated. Please consult Distribution Engineering Intranet Site [Distribution Engineering](#) or <http://distribution>, for the current version prior to use.

5.10 **Corrosive Cable Environments** - Where cables are installed in a corrosive environment, a non-corrosive jacket shall be used on the cable. In addition, cables exposed to sunlight or other forms of ultraviolet radiation shall have an approved jacket suitable for the application.

5.11 **Feeder Separation**

5.11.1 **Primary Service Feeder separation outside the Customer's substation:**

5.11.1.1 For all contingency areas, primary service feeders shall be segregated such that no more than one feeder band (two primary service feeders) shall be installed on a common pole, or within the same ductbank or manhole.

5.11.1.2 A minimum of twenty feet shall separate feeder bands regardless of the contingency design.

5.11.2 **Primary Service Feeders inside the Customer's substation:**

5.11.2.1 For customers with services designed to first contingency requirements - All primary service feeders shall be concrete encased up to the Customer's Primary Service Feeder pothead cubicle.

5.11.2.2 For customers with services designed to second contingency requirements - A minimum of ten foot separation must be maintained between feeders. Primary service feeders installed in conduits in switchgear equipment rooms separated by less than ten (10) feet between feeder bands, shall be concrete encased up to the primary service feeder pothead cubicle.

Specification	Revision	Rev Date	Effective Date	Copyright Information	Page
EO – 2022	15		12/31/2009	1966-2009 Consolidated Edison Co. of New York, Inc.	37 / 81
<b>Filing Information</b>		Application and Design		Manual No. 4	

Paper copies of procedures and instructions are uncontrolled and therefore may be outdated. Please consult Distribution Engineering Intranet Site [Distribution Engineering](#) or <http://distribution>, for the current version prior to use.

**5.11.2.3** No more than two Primary Service Feeder switchgear line-ups shall occupy a switchgear room. The switchgear room walls shall be two (2) hour fire rated walls constructed of concrete block or reinforced masonry. Exception: For adjoining switchgear rooms the common firewall will not be required if there is a minimum spacing of twenty feet between the switchgear lineups associated with the identified feeder bands.

**5.11.2.4** Conduits housing primary feeders that are installed in high traffic areas shall be concrete encased to a height of eight feet above the finished floor.

5.12 **Underground Primary Service Feeder Conduit Installations** - All underground primary service feeder cables shall be installed in conduit. As an exception, where allowed by the Company and Municipal Code, direct buried cables may be installed in accordance with Company Specification EO-6224.

5.13 **Conduit Sizing** - Primary service feeder conduits supplied by the Customer shall be sized to meet, the New York City Electrical Code, Westchester County Code, or Municipality Rules, for the number of feeders and size of the service neutral cables being installed. Each conduit shall have a minimum inside diameter of four inches regardless of code sizing.

5.14 **Conduit Types** - Conduits for primary cable may be of precast concrete, steel, high density polyethylene (HDPE) or fiberglass. All primary cable conduits, except precast concrete type, which are installed in heavily loaded areas such as roadways, streets and under power transformers, shall be concrete encased. All conduit ends shall be flared.

5.15 **Spare Conduits** - Each duct bank shall contain a minimum of two spare conduits, to facilitate repairs and minimize outage time caused by duct obstructions. The spare conduits shall be sealed and capped at both ends against penetration of water and gases.

Specification	Revision	Rev Date	Effective Date	Copyright Information	Page
EO – 2022	15		12/31/2009	1966-2009 Consolidated Edison Co. of New York, Inc.	38 / 81
<b>Filing Information</b>		Application and Design		Manual No. 4	

Paper copies of procedures and instructions are uncontrolled and therefore may be outdated. Please consult Distribution Engineering Intranet Site [Distribution Engineering](#) or <http://distribution>, for the current version prior to use.

5.16 **Property Line Manholes** - Property line manholes shall be furnished and installed by the Customer and shall be in accordance with the Company's specifications. Each duct entrance shall be flared. The Customer shall submit for approval, specifications for manholes differing from those required by the Company.

5.17 **Arcproofing** - Arcproofing of primary cables within Customer manholes is required when more than one feeder is installed within the manhole. Each primary service feeder cable shall be arcproofed in accordance with Specification EO-6025.

6.0 **REVENUE METERING** – The requirements listed below are the more general requirements that would be typical for most the revenue metering at high tension installations. The revenue metering requirements are provided in detail in the Company Revenue Metering Specification MES-350.

6.1 **Mounting Facilities** - The Customer shall furnish, install and maintain mounting facilities and wiring for Company meters, revenue metering instrument transformers, meter devices and phasing receptacles in accordance with Company Specification MES-350 and its support documents.

6.2 **Revenue Metering Instrument Transformers** - Revenue metering instrument transformers shall be mounted at a minimum distance of 6 inches and a maximum of 84 inches from the cubicle floor. All revenue metering transformers are supplied by the Company. 15 kV class revenue metering voltage transformers are primary fused. Other voltage class revenue metering voltage transformers are not primary fused.

6.3 **Metering Cubicles** - Metering cubicles shall be constructed with **separate compartments** for the Company's Revenue Metering Voltage and Current Instrument Transformers. The metering cubicle shall be located next to the primary service feeder termination cubicle and before all other service disconnect or grounding devices. The revenue metering voltage transformers shall be connected on the line side of the current transformers. The dimensions for the Minimum Clearance of Live Parts are found in The 2008 National Electrical Code, Table 490.24. All high voltage connections shall be insulated in a Company approved manner as noted in paragraph 7.7. The

Specification	Revision	Rev Date	Effective Date	Copyright Information	Page
EO – 2022	15		12/31/2009	1966-2009 Consolidated Edison Co. of New York, Inc.	39 / 81
<b>Filing Information</b>		Application and Design		Manual No. 4	

Paper copies of procedures and instructions are uncontrolled and therefore may be outdated. Please consult Distribution Engineering Intranet Site [Distribution Engineering](#) or <http://distribution>, for the current version prior to use.

Company will furnish the revenue metering specifications and transformer mounting dimensions after the Customer signs the site specific specification.

- 6.4 **Phasing Receptacles** - Two phasing receptacles, from different feeders, shall be installed on the front of each Company Metering cubicle. In addition, the Customer shall furnish, install and connect all required conduit and wire for connection of the phasing receptacles. For installations with three or more supply feeders phasing receptacle feeder reference connections shall roll over. For example, for an installation with three feeders the second phasing receptacle on feeder one shall be referenced from feeder two, the second phasing receptacle on feeder two shall be referenced from feeder three and the second phasing receptacle on feeder three shall be referenced from feeder one.
- 6.5 **Customer's Equipment** - Customer's equipment or protective devices shall not be connected to the secondary windings of the Company's Revenue Metering Transformers (The NYCTA has been granted permission to connect a phase-sequence voltage relay, 47 device, to the metering voltage transformers by agreement with the Company).

7.0 **SWITCHGEAR**

- 7.1 **Applicable Standards** - Customers shall provide a primary service feeder interrupting device for each primary service feeder. All switchgear shall be manufactured and tested in accordance with the latest applicable IEEE (ANSI) C37 series and NEMA standards unless amended herein.
- 7.2 **Switchgear Construction** – Metal Clad primary switchgear is required for all 27 kV and 33 kV customer substations and for 13 kV customer substations located in Manhattan, Brooklyn, Queens, and the Bronx. Metal Clad (circuit breaker) or Metal Enclosed (disconnect switch) primary service feeder switchgear shall be constructed as individual free standing, dead front type enclosures which include; meters, relays, metering and relay instrument transformers, interlocks and accessories. Flexible bus links, shall be insulated to the BIL rating of the bus. Due to the high available fault currents on the Company system, the use of Metal Enclosed primary switchgear is limited to the 4kV system and some of the 13 kV systems in Westchester and Staten

Specification	Revision	Rev Date	Effective Date	Copyright Information	Page
EO – 2022	15		12/31/2009	1966-2009 Consolidated Edison Co. of New York, Inc.	40 / 81
<b>Filing Information</b>		Application and Design		Manual No. 4	

Paper copies of procedures and instructions are uncontrolled and therefore may be outdated. Please consult Distribution Engineering Intranet Site [Distribution Engineering](#) or <http://distribution>, for the current version prior to use.



Island. Customer primary service feeder interrupting device(s) and associated switchgear shall be approved by the Company. Previous circuit breaker/switchgear manufacturers that have been deemed acceptable for use by Customers receiving high tension service (at varying voltage levels) will be provided upon request.

Customers deciding to utilize switchgear not previously reviewed and approved by the Company will be required to submit for Company review third party certified test reports by an independent test laboratory (e.g., KEMA) documenting the proposed switchgear has successfully met the IEEE(ANSI) design test requirements. In either case it is recommended that the Customer discuss the particulars for their project and submit this documentation as early in the process as possible in order to obtain Company acceptance prior to purchase and avoid delays.

7.3 **Outdoor Switchgear** – All Outdoor switchgear shall be a Company approved walk-in sheltered aisle switchgear. The sheltered aisle switchgear shall have; thermostatically controlled heating and ventilation systems suitably sized strip heaters, a telephone connected to an outside line and polarized 120V power convenience outlets. Outdoor switchgear shall have a metal canopy which will extend over the switchgear to cover the full door extension on both control and equipment cubicles sides.

7.4 **Outdoor Switchgear Doors** - NEMA approved weatherproof doors are required for all outdoor switchgear. A sheltered aisle doors (located at each end of the aisle) shall be equipped with a quick release mechanism with a full width actuator on the inside of the door and shall be capable of being opened from the inside, even if locked on the outside.

7.5 **Indoor Switchgear Rooms** - Quick release mechanisms with full width actuators are required on all indoor switchgear room doors. All exit doors (minimum of two per room) shall be capable of being opened from the inside, if locked on the outside and shall have a clear path to exit in an emergency. All indoor switchgear rooms shall have thermostatically controlled heating and ventilation in addition to polarized convenience outlets.

Specification	Revision	Rev Date	Effective Date	Copyright Information	Page
EO – 2022	15		12/31/2009	1966-2009 Consolidated Edison Co. of New York, Inc.	41 / 81
<b>Filing Information</b>		Application and Design		Manual No. 4	

Paper copies of procedures and instructions are uncontrolled and therefore may be outdated. Please consult Distribution Engineering Intranet Site [Distribution Engineering](#) or <http://distribution>, for the current version prior to use.

7.6 **Switchgear Ratings** - ALL switchgear, shall be **Load Break** type, electrically operated with a motor charged stored energy mechanism for both tripping and closing. A nameplate on the primary interrupting device shall state the **short circuit interrupting current rating at the operating voltage**. The means of load and fault interruption can be Air, Vacuum or SF6. See minimum ratings in table below:

Rated Maximum kV, rms	Rated BIL kV	Rated Cont's kA, rms	Rated S.C. KA @ Max. kV	Rated V. Range K Factor	Close & Latch Capability kA Crest (Peak)
4.76	60.0	1.2/2.0/3.0	29/41	1.24/1.19	97/132
4.76	60.0	1.2/2.0/3.0	40/50	1.0	104/130
15.0	95.0	1.2/2.0/3.0	37.0	1.3	130
15.0	95.0	1.2/2.0/3.0	50	1.0	130
38.0	150.0*	1.2/2.0/3.0	21.0	1.65	95
**38.0	150.0*	1.2/2.0/3.0	31.5	1.0	82

\*200 kV BIL shall be used for outdoor equipment

\*\*Only for Staten Island 33 kV applications

7.6.1 Current limiting fuses or similar devices are not considered adequate to obtain the ratings given in the above table.

7.7 **Switchgear Bus** - Switchgear **Bus** and **Bus Connections** shall have an insulated covering which fully insulates the bus to the BIL ratings given in the above table and meets or exceeds the ampere rating of the bus disconnect device.

7.8 **Ground Bus** – The switchgear ground bus shall be present in all compartments where grounding of the equipment contained in the compartment is required. Equipment ground wires shall not penetrate compartment walls in order to connect to the switchgear ground bus.

Specification	Revision	Rev Date	Effective Date	Copyright Information	Page
EO – 2022	15		12/31/2009	1966-2009 Consolidated Edison Co. of New York, Inc.	42/81
<b>Filing Information</b>		Application and Design		Manual No. 4	

Paper copies of procedures and instructions are uncontrolled and therefore may be outdated. Please consult Distribution Engineering Intranet Site [Distribution Engineering](#) or <http://distribution>, for the current version prior to use.

- 7.9 **Grounding Devices** – Grounding devices shall meet all the operating voltage and current requirements for switchgear as noted in paragraph 7.6 except for the fault interrupting requirements.
- 7.10 **Cubicle Doors** - All medium voltage cubicles (front and rear) shall be accessible through padlockable hinged doors. There shall be no exposed low voltage wiring in any medium voltage cubicles.
- 7.11 **Barriers and Insulators** - All penetrations (bus, wiring, etc.) between adjacent switchgear cubicles shall be through Company approved barriers and insulators.
- 7.12 **Shutters** - Drawout type circuit breaker switchgear cubicles shall be constructed with shutters to cover the stationary contacts when the circuit breaker is racked out of the cubicle. These shutters shall be mechanically interlocked with the positioning of the breaker unit to ensure proper opening and alignment with the racking in and out of the circuit breaker. It is recommended that the shutters be metallic and of suitable strength to protect against possible damage due to mechanical misalignment during circuit breaker insertion.
- 7.13 **Stop Blocks** - Stop blocks shall inhibit any Ground and Test (G&T) device from entering a Tie circuit breaker cubicle or any cubicle in which the G&T device can inadvertently ground a paralleling bus .
- 7.14 **Circuit Breaker Trip Interlocks** - All circuit breaker and storage cubicles shall be equipped with a trip free interlock. All circuit breakers and G&T devices shall trip free if in the closed position upon insertion and removal from a cubicle.
- 7.15 **Fixed Type Circuit Breakers** - Fixed type circuit breakers shall have a load break disconnect switch installed on its line and load side. A ground switch shall be installed Company side of the line side disconnect switch. The Company shall approve the Customer’s interlock arrangement between the disconnect switch, ground switch and the fixed type circuit breaker.

Specification	Revision	Rev Date	Effective Date	Copyright Information	Page
EO – 2022	15		12/31/2009	1966-2009 Consolidated Edison Co. of New York, Inc.	43 / 81
<b>Filing Information</b>		Application and Design		Manual No. 4	

Paper copies of procedures and instructions are uncontrolled and therefore may be outdated. Please consult Distribution Engineering Intranet Site [Distribution Engineering](#) or <http://distribution>, for the current version prior to use.

7.16 **Fused Loadbreak Disconnect Switches** - Fused loadbreak disconnect switches which are used as primary disconnect devices shall be electrically operable from a remote panel and shall **NOT** have their control switches mounted on the compartment doors of the devices they are operating. The control switches shall be mounted on a separate control panel with a mimic bus, which shows equipment layout for the remote operation and status indication of the disconnect switches. The control panel can be installed at one end of the switchgear lineup, or at a remote location inside the switchgear room. Fused loadbreak disconnect switches will be permitted on all 4 kV primary systems and on certain 13 kV primary systems in Staten Island and Westchester. A 125VDC power supply, with a charger, shall be used for all relay and control functions.

7.17 **Locking** - G&T devices shall be able to be locked in any operating position (open, closed, ground and disconnect position). Fixed type circuit breakers shall be equipped with a key interlock to lock the circuit breaker in the open position. Draw out type circuit breakers shall be equipped with a key interlock to lock the circuit breaker in the disconnect position. Loadbreak disconnect switches shall be equipped with a key interlock to lock the disconnect switch in the open position. Additional locks may be required by the Company for specific applications.

7.18 **Low Voltage Power Supply** - The Customer shall install a suitably sized low voltage power supply for heaters, transformer cooling fans, receptacles, internal and external lighting, etc. Any instrument transformer installed before the first point of disconnection must have Company approval and be connected phase to phase. The instrument transformer shall be able to withstand the Company cable proof testing values given in Company Specification EO-4019.

7.19 **Circuit Breaker Trip Coils** - All circuit breaker trip coil circuits shall be interlocked with a normally open auxiliary breaker contact, to open the trip coil circuit when the tripping coil has operated. All circuit breaker trip coils shall be separately monitored with Company approved monitoring devices.

7.20 **Circuit Breaker Control Switches** - The primary service feeder and tie circuit breakers shall **NOT** have their control switches mounted on the compartment

Specification	Revision	Rev Date	Effective Date	Copyright Information	Page
EO – 2022	15		12/31/2009	1966-2009 Consolidated Edison Co. of New York, Inc.	44 / 81
<b>Filing Information</b>		Application and Design		Manual No. 4	

Paper copies of procedures and instructions are uncontrolled and therefore may be outdated. Please consult Distribution Engineering Intranet Site [Distribution Engineering](#) or <http://distribution>, for the current version prior to use.

doors of the devices they are operating. The control switches shall be mounted on a separate control panel with a mimic bus, which shows equipment layout for the remote operation and status indication of the circuit breakers or disconnect switches. The control panel can be installed at one end of the switchgear lineup, or at a remote location inside the switchgear room. The control panel shall have direct unobstructed access to an exit. The exit path shall not pass by the controlled switchgear.

7.21 **Maneuvering Switchgear** - The Customer shall provide a convenient means for maneuvering all drawout type switchgear, and G&T devices (e.g., Dolly, 5th Wheel, etc.).

**8.0 MECHANICAL, ELECTRICAL, KEY INTERLOCKS AND AUTOMATIC TRANSFER**

8.1 **Key Codes** - Key Interlocks shall be installed to avoid inadvertent and unauthorized switchgear operation movements. Where key interlocks are employed, each primary service feeder device shall be furnished with an individual key code that is not operable with any other key interlock within the Customer's system. Key codes for other devices shall be furnished as noted in other paragraphs in Section 8.0. A key interlock system shall inhibit all electrical operations except for those operations that are performed in the test mode.

8.2 **Fixed Type Circuit Breakers** - Fixed type circuit breakers shall be designed with a line and load side disconnect switch. A fixed type circuit breaker and line and load side disconnect switch combination shall be furnished with key interlocks such that opening and closing of the disconnect switches is inhibited when the breaker is closed. The key code shall be restricted to the breaker and disconnect switch combination.

8.3 **Fused Disconnect Switch Cubicle Entry** - Key interlocks shall inhibit the changing a power fuse in a fused disconnect switch cubicle unless all power sources to the fuses are locked open. Barriers and warning signs shall be installed to prevent accidental contact with any energized cubicle components when the fuses must be replaced.

Specification	Revision	Rev Date	Effective Date	Copyright Information	Page
EO – 2022	15		12/31/2009	1966-2009 Consolidated Edison Co. of New York, Inc.	45 / 81
<b>Filing Information</b>		Application and Design		Manual No. 4	

Paper copies of procedures and instructions are uncontrolled and therefore may be outdated. Please consult Distribution Engineering Intranet Site [Distribution Engineering](#) or <http://distribution>, for the current version prior to use.

- 8.4 **Ground Switch Interlocks** - Ground switch and drawout circuit breaker or ground switch and primary service feeder disconnect switch combinations shall be key interlocked such that the ground switch is operable only when the line disconnecting device is **locked open** and there is no voltage on the primary service feeder. **The interior of the ground switch compartment shall only be accessible when the ground switch is in the closed (ground) position.**
- 8.5 **Key Tagging and Key Storage Box** - Every interlock key shall be tagged with a brass key tag. All spare interlocking keys for primary, secondary switchgear and G&T devices shall be delivered to the Company. All keys designated as Company keys shall be turned over in **TOTAL**. The Customer shall furnish and install, in a convenient location, a **Key Storage Box** that will be padlocked by the Company.
- 8.6 **Multi-Feeder Radial Installation Interlocks** - At multi-feeder RADIAL type installations, the Customer's primary service and secondary feeders shall be interlocked to ensure that no Customer device can be closed to parallel feeders at any point in the Customer's internal distribution system. Bus Tie circuit breaker(s) shall be purchased with a by-pass key, allowing the Company to parallel feeders during scheduled work or when the system is returned to normal. The by-pass key is used only by the Company personnel and is locked in the Key Storage Box.
- 8.7 **Key Interlocking Sequence** - The Company shall approve the Customer's break before make mechanical key interlocking sequence. Customer operating personnel shall be trained in the operation of the key interlocking sequence and shall follow a Company approved Customer Operating Specification. Laminated key sequence operating instructions shall be prominently displayed at the project site.
- 8.8 **Electrical Interlocks** - In addition to the other interlocking requirements detailed in Section 8.0, the electrical interlocking system shall be designed as follows:
- 8.8.1 The primary service circuit breaker shall be electrically interlocked with the transformer main circuit breaker so that the transformer main circuit

Specification	Revision	Rev Date	Effective Date	Copyright Information	Page
EO – 2022	15		12/31/2009	1966-2009 Consolidated Edison Co. of New York, Inc.	46 / 81
<b>Filing Information</b>		Application and Design		Manual No. 4	

Paper copies of procedures and instructions are uncontrolled and therefore may be outdated. Please consult Distribution Engineering Intranet Site [Distribution Engineering](#) or <http://distribution>, for the current version prior to use.

breaker cannot be closed unless the primary service circuit breaker is closed.

8.8.2 The transformer main circuit breaker shall trip whenever the primary service circuit breaker is opened.

8.9 **Remote Electrical Control Systems** - Remote Electrical Control Systems which permit the opening and closing of circuit breakers from a dispatch control room shall have a system designed to meet all applicable conditions stated in Sections 8.0 and 10.0 in addition to the following:

8.9.1 The Customer who applies for remote control system **must** have qualified operating personnel on duty, 7 days a week on a 24 hour a day basis.

8.9.2 The Customer's qualified operating personnel must secure permission from the Company's District Operator **before** any operations are performed.

8.9.3 The Customer must get the District Operator's permission prior to shifting the load, from one primary service feeder to another.

8.9.4 Updated relay and control schematics for the remote control system must be submitted to the Company for approval and record.

8.9.5 The maximum response of one hour is required by the Customer during Company contingency conditions. Failure to meet the one hour response time shall only be excusable when it is beyond the Customers control; i.e., severe weather, riots, floods, fires, etc.

8.9.6 For scheduled work on Company feeders the Customer will be given 12 hour advance notice. The Customer shall rack-out his breakers and have the feeder position accessible for grounding (if necessary).

8.9.7 If the maximum response time is not adhered to, the right to use remote electrical control will be withdrawn and mechanical interlocks will be required.

Specification	Revision	Rev Date	Effective Date	Copyright Information	Page
EO – 2022	15		12/31/2009	1966-2009 Consolidated Edison Co. of New York, Inc.	47 / 81
<b>Filing Information</b>		Application and Design		Manual No. 4	

Paper copies of procedures and instructions are uncontrolled and therefore may be outdated. Please consult Distribution Engineering Intranet Site [Distribution Engineering](#) or <http://distribution>, for the current version prior to use.

8.10 **Automatic Transfer** - Automatic Transfer of Radial feeders will be permitted for Critical Customers. There shall be no paralleling of circuit breakers during the transfer operation; all automatic operations are break-before-make. The Customer shall test and maintain the automatic transfer equipment as detailed in Company Specification EO-4035 with the following exceptions; the relays shall be tested and the certified test reports submitted to the Company every 48 months. Failure to submit test reports may result in withdrawal of permission to use the automatic transfer system and key interlocks will be required.

8.11 **Automatic Transfer Function Guide** - The Automatic Load Transfer system shall function as follows:

8.11.1 Normal Status:

- a. Both primary service feeder circuit breakers are closed and carrying load.
- b. The bus tie breaker is open.

8.11.2 When one of the Customer's primary service feeder circuit breaker trips, the Customer's bus tie breaker will close after a time delay of one to ten seconds. To accomplish the autotransfer, the control circuitry **must** check the following:

- a. There is **no voltage** present on the load side of the now opened primary service feeder circuit breaker.
- b. **No fault current** has passed through the now opened Customer line circuit breaker.
- c. The Customer's primary service feeder circuit breaker did not fail to open to clear the fault on the Customer's premises.

Specification	Revision	Rev Date	Effective Date	Copyright Information	Page
EO – 2022	15		12/31/2009	1966-2009 Consolidated Edison Co. of New York, Inc.	48 / 81
<b>Filing Information</b>		Application and Design		Manual No. 4	

Paper copies of procedures and instructions are uncontrolled and therefore may be outdated. Please consult Distribution Engineering Intranet Site [Distribution Engineering](#) or <http://distribution>, for the current version prior to use.



d. There is **normal voltage** present on the load side of the companion primary service feeder circuit breaker that will pick-up the load.

8.11.3 When there is a fault condition on the load side of the primary service feeder circuit breaker, the primary service feeder circuit breaker will trip, and the automatic transfer control circuitry shall inhibit transfer and the shall check the following:

- a. The primary service feeder circuit breaker has opened.
- b. The Bus Tie circuit breaker has been blocked from closing.

8.11.4 Return to Normal Operation (Company controlled manual by-pass key operation)

- a. Normal three phase voltage must be present on the line side of the open primary service circuit breaker.
- b. Phase sequence checks shall be made across the open primary service circuit breaker.
- c. The primary service circuit breaker is closed.
- d. The bus tie circuit breaker is opened to restore the system to normal.

8.12 **Automatic Transfer - Interlocks and Relays** - Automatic Transfer electrical interlocking and protective relaying systems shall be designed to accomplish the following:

8.12.1 The bus tie circuit breaker cannot be closed after **both** primary service feeder circuit breakers are closed (can be defeated with a manual by-pass key).

8.12.2 The bus tie breaker cannot be closed if a fault condition exists on the load side of the either line circuit breaker or on the tie bus.

Specification	Revision	Rev Date	Effective Date	Copyright Information	Page
EO – 2022	15		12/31/2009	1966-2009 Consolidated Edison Co. of New York, Inc.	49 / 81
<b>Filing Information</b>		Application and Design		Manual No. 4	

Paper copies of procedures and instructions are uncontrolled and therefore may be outdated. Please consult Distribution Engineering Intranet Site [Distribution Engineering](#) or <http://distribution>, for the current version prior to use.

8.12.3 A time delay shall inhibit transfer during voltage dips.

8.12.4 Retransfer of load is reestablished manually under Company jurisdiction.

8.12.5 Facilities shall exist to allow the paralleling of the feeders to prevent Customer outages during system restoration and scheduled outages. During the paralleling operation, performed by Company employees, both primary service feeder and tie circuit breakers shall activate a timer to trip the tie breaker. The timer shall be adjustable 0-60 seconds; settings will be given at the time of installation.

8.12.6 An alarm system shall be installed to alert the Customer's operator that a transfer has occurred or the selector switch has been left in the bypass position. When the alarm is activated, the Customer must call the Company's District Operator for instructions.

8.13 **Programmable Logic Controller (PLC)** - The Customer will be permitted to use a PLC for system controls and alarm. Back-up signals shall be provided via a hard-wire system for the tripping of the circuit breaker trip coils.

9.0 **GROUNDING DEVICES** - The Customer shall provide the means for grounding the primary service feeder. Acceptable means for grounding the primary service feeder devices are G&T Devices and motor operated ground switches.

#### 9.1 **GROUND & TEST (G&T) DEVICE**

9.1.1 **Function and Storage** - A Customer choosing to furnish a G&T device for grounding of the primary service feeder shall maintain the G&T device at the facility. A minimum of one G&T device shall be provided for installations with up to four primary service feeders. The Company may require additional G&T devices for installations with five or more feeders. The G&T device shall be available for all primary service feeders. If the G&T device cannot be moved to all primary service feeders then additional G&T devices shall be provided. The G&T device, used for primary service feeder grounding

Specification	Revision	Rev Date	Effective Date	Copyright Information	Page
EO – 2022	15		12/31/2009	1966-2009 Consolidated Edison Co. of New York, Inc.	50/81
<b>Filing Information</b>		Application and Design		Manual No. 4	

Paper copies of procedures and instructions are uncontrolled and therefore may be outdated. Please consult Distribution Engineering Intranet Site [Distribution Engineering](#) or <http://distribution>, for the current version prior to use.

and testing shall be manufactured to occupy the same cubicle normally occupied by the primary service feeder circuit breaker. The G&T device shall be locked in a Company approved storage cubicle when not in use. The G&T device shall be rated to meet all voltage and current requirements as the primary service breaker except for the fault interrupting rating.

- 9.1.2 **Key Interlocking** - The G&T device shall be equipped with a key interlock system to allow for grounding and testing of the Company's primary service feeders. The keys that Company personnel will use to initiate the G&T grounding and testing operations are kept under Company jurisdiction in the Company's Key Storage Box.
- 9.1.3 **Trip and Close Controls** - Facilities shall be provided to operate (trip and close) the G&T device from a remote position by an extension cord (approximately twenty five feet long) with push-button controls.
- 9.1.4 **Dual Function G&T Devices** - The Company will permit the Customer to use either separate G&T devices for Company and Customer use or a dual function G&T device for Company and Customer use. The key and mechanical interlocking system for the dual function G&T devices is much more complex and the following additional requirements are imposed:
  - An additional key is required on the manual operator which selects between the Customer and Company modes of operation.
  - Additional keys shall be obtained from the associated main secondary circuit breaker and tie circuit breaker (if any).

The G&T device shall be interlocked so that only the Company's primary service feeder or Customer's installation can be grounded at any one time. Transfer from the Company's position to Customer's position shall be accomplished with a key interlock and shall be inhibited when the G&T device is in the cubicle. The G&T device, when not in use, shall be stored in set to the Customer mode of

Specification	Revision	Rev Date	Effective Date	Copyright Information	Page
EO – 2022	15		12/31/2009	1966-2009 Consolidated Edison Co. of New York, Inc.	51 / 81
<b>Filing Information</b>		Application and Design		Manual No. 4	

Paper copies of procedures and instructions are uncontrolled and therefore may be outdated. Please consult Distribution Engineering Intranet Site [Distribution Engineering](#) or <http://distribution>, for the current version prior to use.

operation in a storage cubicle that is padlocked with a Company lock. The manual operator shall be plainly marked as **CUSTOMER** and **CON EDISON**.

9.1.5 **Test Receptacles** - To test the Company’s primary service feeder, three, fully rated voltage test receptacles shall be provided on the front of the G&T device which provide individual connections to each phase of the LINE side of the G&T device. Testing of Customer’s LOAD side equipment shall also be accomplished via fully rated, voltage test receptacles, which are key interlocked to ensure a safe operation.

9.1.6 **Receptacle Shutters** - All test receptacles shall be furnished with shutters to isolate the receptacles while not in use. The shutters shall be key interlocked with the manual operator in such a manner that they cannot be opened unless the G&T device is in the mode of operation assigned and the G&T device is closed (ground is applied). The key interlock shall allow the G&T device to be tripped open only after the test receptacle shutters are closed or after the test probes are inserted and locked into the receptacles. The test receptacles shall be interlocked with the operation of the G&T device to ensure that the probes can **only** be removed when the G&T device is in the **ground** position.

9.1.7 **Test Probes and Cables** - One set of **test probes** and with 25 length foot **cables** shall be furnished with each G&T device. The probes and cables shall be stored at the site. The cables shall have the same insulation voltage rating as the associated switchgear. The test cables shall be furnished with a lug for attachment to a test set.

9.1.8 **G&T device - Interlocking Requirements** - The switchgear manufacturer shall provide a G&T device which will meet the Company’s interlocking requirements. To initiate grounding and testing of a Company feeder, Company personnel will obtain a **KU Key** from the key storage box on the premises. **The KU Key** will be used to begin a series of interlocking moves that ensure that the G&T device will be operated in a safe manner. The following describes the

Specification	Revision	Rev Date	Effective Date	Copyright Information	Page
EO – 2022	15		12/31/2009	1966-2009 Consolidated Edison Co. of New York, Inc.	52/81
<b>Filing Information</b>		Application and Design		Manual No. 4	

Paper copies of procedures and instructions are uncontrolled and therefore may be outdated. Please consult Distribution Engineering Intranet Site [Distribution Engineering](#) or <http://distribution>, for the current version prior to use.

G&T interlocks and the sequence of moves that will ground the feeder:

- 9.1.8.1 **Key Lock #1 (Keys KU & KB)** - The KU Key is inserted in the G&T device Key Lock #1. The KU/KB Keys are rotated to electrically enable/disable the G&T Device. The KU Key is held captive and the KB Key is released when the G&T device is electrically disabled. The KB Key is held captive and the KU Key is released when the G&T device is electrically enabled.
- 9.1.8.2 **Key Lock #2 (Keys KB & KC)** – The KB Key is inserted in Key Lock #2. The KB/KC Keys are rotated to mechanically lock the G&T Device in the open position. The KB Key is held captive and the KC Key is released when the G&T device is mechanically locked. The KC Key is held captive and the KB Key is released when the G&T device is mechanically unlocked.
- 9.1.8.3 **Key Lock #3 (Key KC)** - The KC Key is used to unlock the “lifting lever” that prevents the G&T device from being inserted in the cubicle or that locks the G&T device in the cubicle. The KC Key is held captive in when the “lifting lever” is unlocked.
- 9.1.8.4 **Key Lock #4 (Keys KB & KD)** - The KB Key is inserted in Key Lock #4 to mechanically lock the G&T Device in the closed position; the KB Key is held captive and the KD Key is released when the G&T device is mechanically locked in the closed position.
- 9.1.8.5 **Key lock #5 (Key KD)** - The KD Key is used to open and lock the Test Port Shutters. The KD Key is held captive when the Test Port Shutters are unlocked. The KD Key is released when the Test Port Shutters are locked in the covered position or when the Test Port Shutters have locked the Test Probes in the Test Ports.

Specification	Revision	Rev Date	Effective Date	Copyright Information	Page
EO – 2022	15		12/31/2009	1966-2009 Consolidated Edison Co. of New York, Inc.	53/81
<b>Filing Information</b>		Application and Design		Manual No. 4	

Paper copies of procedures and instructions are uncontrolled and therefore may be outdated. Please consult Distribution Engineering Intranet Site [Distribution Engineering](#) or <http://distribution>, for the current version prior to use.

9.1.8.6 **Selector Switch** - A three-position pistol grip switch - Trip/Off/Close. The Selector Switch shall be pad lockable in the Off position.

9.1.8.7 **Padlockable Cover** - Covers the manual Trip Push-button

9.1.8.8 **Push-button Station** – Open and Close buttons located at the end of a 25 foot extension cord that is used to Trip and Close the G&T device.

## 9.2 **GROUND SWITCHES**

9.2.1 **Function** – Customers who utilize fused loadbreak disconnect switches as primary disconnect devices shall provide a line side ground switch for each primary service feeder. Ground switches may be provided in lieu of a G&T device for installations equipped with circuit breakers as the primary disconnect devices. Ground switches shall be installed in separate compartments when used with circuit breakers. Ground switches shall be electrically operable from a remote panel and shall **NOT** have their control switches mounted on the compartment doors of the devices they are operating. The control switches shall be mounted on a separate control panel with a mimic bus, which shows equipment layout for the remote operation and status indication of the ground switches. The control panel can be installed at one end of the switchgear lineup, or at a remote location inside the switchgear room.

9.2.2 **Key Interlocking** - The ground switches shall be equipped with a key interlock system to allow for grounding of the Company's primary service feeders. The keys that Company personnel will use to initiate the G&T grounding and testing operations are kept under Company jurisdiction in the Company's Key Storage Box.

9.2.3 **Ground Switch Interlocking Requirements** - The following describes the required key, mechanical and electric interlocks of

Specification	Revision	Rev Date	Effective Date	Copyright Information	Page
EO – 2022	15		12/31/2009	1966-2009 Consolidated Edison Co. of New York, Inc.	54/81
<b>Filing Information</b>		Application and Design		Manual No. 4	

Paper copies of procedures and instructions are uncontrolled and therefore may be outdated. Please consult Distribution Engineering Intranet Site [Distribution Engineering](#) or <http://distribution>, for the current version prior to use.

the electrically operated disconnect switch and the associated ground switch.

#### 9.2.4 **Device Descriptions**

9.2.4.1 **Utility Lockbox (Key KU)** – Padlockable box located on the premises for Utility use. This lockbox houses the KU Key.

9.2.4.2 **Selector Switch** - A three-position pistol grip switch located on the Ground Switch cubicle - Open/Off/Close.

9.2.4.3 **Remote Control Panel** – Operator’s panel with mimic bus located away from the front of the switchgear compartment to permit operation of the Line and Ground Switches. Indicating lights are provided to show the open and close status for each remotely operated device.

9.2.4.4 **Remote Control Switch** - A three-position pistol grip switch located on the Remote Control Panel - Open/Close, return to center [after open (green flag) and after close (red flag)].

9.2.4.5 **Padlockable Cover** – Manual Trip and Close Push-buttons located on the Ground Switch cubicle are equipped with a padlockable cover for Utility use.

9.2.4.6 **Key Lock #1 (Key KB)** – Key operated switch located on the Utility Disconnect Switch cubicle that mechanically locks the Utility Disconnect Switch in the open position and electrically disables the motor operated Disconnect Switch. Key KB is held captive when the Disconnect Switch is closed. Key KB is released when the Disconnect Switch is opened. The disconnect switch can be operated only when KB is in Key Lock #1 and rotated to the captive position.

9.2.4.7 **Key Lock #2 (Keys KU, KB & KC)** – Key operated switch and interlock located on the Utility Ground Switch cubicle that electrically disables the motor operated Utility Ground

Specification	Revision	Rev Date	Effective Date	Copyright Information	Page
EO – 2022	15		12/31/2009	1966-2009 Consolidated Edison Co. of New York, Inc.	55/81
<b>Filing Information</b>		Application and Design		Manual No. 4	

Paper copies of procedures and instructions are uncontrolled and therefore may be outdated. Please consult Distribution Engineering Intranet Site [Distribution Engineering](#) or <http://distribution>, for the current version prior to use.

Switch and locks the Selector Switch in the Off position. Key KC is held captive. Key KC will be designated Key KC1 when Key Lock #5 is present. Inserting Key KU and Key KB in Key Lock #2 lets the operator rotate all three keys and release Key KC. When Key KC is released Key KU and Key KB are held captive, the motor operator is electrically enabled and the Selector Switch can be moved to the Open or Close positions.

9.2.4.8 **Key Lock #3 (Keys KC & KD)** - Key operated interlock located on the Utility Ground Switch cubicle that mechanically locks the Utility Ground Switch in the open or closed positions and prevents inadvertent operation in the event of a failure in the Ground Switch electrical system. If the mechanical design of the Ground Switch precludes the possibility of using a single lock to mechanically lock the Ground Switch in both the open and closed positions then Key Lock #2 will mechanically lock the Ground Switch in the open position and Key KC will be designated Key KC1. Key KD is held captive. Inserting Key KC in Key Lock #3 lets the operator rotate both keys and release Key KD. When Key KD is released Key KC is held captive and the Ground Switch is mechanically unlocked.

9.2.4.9 **Key Lock #4 (Key KD)** – Key operated switch located on the remote control panel that electrically enables the Utility Ground Switch Remote Control Switch located on the remote control panel when Key KD is inserted and rotated in Key Lock #4.

9.2.4.10 **Key Lock #5 (Keys KC2 & KD)** - Key operated interlock located on the Utility Ground Switch cubicle that mechanically locks the Utility Ground Switch in the closed position and prevents inadvertent operation in the event of a failure in the Ground Switch electrical system. This key will be required only if mechanical design of the Ground Switch prevents the use of Key Lock #2 to mechanically

Specification	Revision	Rev Date	Effective Date	Copyright Information	Page
EO – 2022	15		12/31/2009	1966-2009 Consolidated Edison Co. of New York, Inc.	56/81
<b>Filing Information</b>		Application and Design		Manual No. 4	

Paper copies of procedures and instructions are uncontrolled and therefore may be outdated. Please consult Distribution Engineering Intranet Site [Distribution Engineering](#) or <http://distribution>, for the current version prior to use.



lock the Ground Switch in the closed position. Key KC2 is held captive. Inserting Key KD in Key Lock #5 lets the operator rotate both keys and release Key KC2. When Key KC2 is released Key KD is held captive and the Ground Switch is mechanically locked in the closed position.

**9.2.5 Sequence 1 To Apply Ground On The Utility Feeder:**

9.2.5.1 **Key Lock #1 (Key KB)** – When the Disconnect Switch is in the closed position the KB Key is held captive in Key Lock #1. When the Disconnect Switch is opened; the KB key can be rotated and removed from Key Lock #1 thereby mechanically locking the Disconnect Switch in the open position and electrically disabling the Disconnect Switch.

9.2.5.2 **Key Lock #2 (Keys KU, KB & KC)** - The KC Key is held captive in Key Lock #2. The KU Key is removed from the Utility Lock Box and the KB key that was previously removed from Key Lock #1 are inserted in the Utility Ground Switch Key Lock #2. The KU/KB/KC Keys are rotated to electrically enable the Ground Switch and unlock the Selector Switch. The KU Key and KB keys are held captive and the KC Key is released.

9.2.5.3 **Selector Switch** - The Selector Switch is rotated to the Close position.

9.2.5.4 **Key Lock #3 (Keys KC & KD)** - The KD Key is held captive in Key Lock #3. The KC Key is inserted in Key Lock #3. The KC/KD Keys are rotated to mechanically unlock the Utility Ground Switch. The KC Key is held captive and the KD Key is released.

9.2.5.5 **Key Lock #4 (Key KD)** – The KD Key is inserted in Key Lock #4 located on the Remote Control Panel and rotated to electrically enable the Utility Ground Switch Remote Control Switch. The operator verifies that the area in front

Specification	Revision	Rev Date	Effective Date	Copyright Information	Page
EO – 2022	15		12/31/2009	1966-2009 Consolidated Edison Co. of New York, Inc.	57/81
<b>Filing Information</b>		Application and Design		Manual No. 4	

Paper copies of procedures and instructions are uncontrolled and therefore may be outdated. Please consult Distribution Engineering Intranet Site [Distribution Engineering](#) or <http://distribution>, for the current version prior to use.

of and in the vicinity of the Utility Ground Switch is clear of personnel and operates the Ground Switch Remote Control Switch to close the Ground Switch.

9.2.5.6 **Key Lock #3 (Keys KC & KD)** - After the Utility Ground Switch is closed, Key KD is removed from Key Lock #4 and inserted in Key Lock #3. The KC/KD Keys are rotated to mechanically lock the Ground Switch in the closed position. The KD Key is held captive and the KC Key is released.

9.2.5.7 **Selector Switch** - The Selector Switch is rotated to the “Off” position.

9.2.5.8 **Key Lock #2 (Keys KU, KB & KC)** – The KC Key is inserted in Key Lock #2. The KU/KB/KC Keys are rotated to electrically disable the Ground Switch and lock the Selector Switch in the OFF position. The KC Key is held captive and the KU & KB Keys are released. The KU & KB Keys may now be removed from Key Lock # 2 and locked in the Utility Lockbox to prevent unauthorized operation of either the Utility Ground Switch or the Disconnect Switch.

9.2.6 **Sequence 2 To Apply Ground On The Utility Feeder :**

9.2.6.1 **Key Lock #1 (Key KB)** – When the Disconnect Switch is closed the KB Key is held captive in Key Lock #1. When the Disconnect Switch is opened; the KB key can be rotated and removed from Key Lock #1 thereby mechanically locking the Disconnect Switch in the open position electrically disabling the Disconnect Switch.

9.2.6.2 **Key Lock #2 (Keys KU, KB & KC1)** – The KC1 Key is held captive in Key Lock #2. The KU Key is removed from the Utility Lockbox and the KB key that was previously removed from Key Lock #1 are inserted in the Ground Switch Key Lock #2. The KU/KB/KC1 Keys are rotated to electrically enable the Ground Switch and unlock the

Specification	Revision	Rev Date	Effective Date	Copyright Information	Page
EO – 2022	15		12/31/2009	1966-2009 Consolidated Edison Co. of New York, Inc.	58/81
<b>Filing Information</b>		Application and Design		Manual No. 4	

Paper copies of procedures and instructions are uncontrolled and therefore may be outdated. Please consult Distribution Engineering Intranet Site [Distribution Engineering](#) or <http://distribution>, for the current version prior to use.

Selector Switch. The KU Key and KB keys are held captive and the KC1 Key is released.

9.2.6.3 **Selector Switch** - The Selector Switch is rotated to the Close position.

9.2.6.4 **Key Lock #3 (Keys KC1 & KD)** – The KD Key is held captive in Key Lock #3. The KC1 Key is inserted in Key Lock #3. The KC1/KD Keys are rotated to mechanically unlock the Ground Switch. The KC1 Key is held captive and the KD Key is released.

9.2.6.5 **Key Lock #4 (Key KD)** – The KD Key is inserted in Key Lock #4 located on the Remote Control Panel and rotated to electrically enable the Utility Ground Switch Remote Control Switch. The operator verifies that the area in front of and in the vicinity of the Utility Ground Switch is clear of personnel and operates the Ground Switch Remote Control Switch to close the Ground Switch.

9.2.6.6 **Key Lock #5 (Keys KC2 & KD)** - After Ground Switch is closed, Key KD is removed from Key Lock #4 and inserted in Key Lock #5. The KD/KC2 Keys are rotated to mechanically lock the Ground Switch in the closed position. The KD Key is held captive and the KC2 Key is released.

9.2.6.7 **Selector Switch** - The Selector Switch is rotated to the Off position.

9.2.6.8 **Key Lock #2 (Keys KU, KB & KC2)** – The KC2 Key is inserted in Key Lock #2 in place of KC1. The KU/KB/KC2 Keys are rotated to electrically disable the Ground Switch and lock the Selector Switch in the OFF position. The KC2 Key is held captive and the KU & KB Keys are released. The KU & KB Keys may now be removed from Key Lock # 2 and locked in the Utility Lockbox to prevent unauthorized

Specification	Revision	Rev Date	Effective Date	Copyright Information	Page
EO – 2022	15		12/31/2009	1966-2009 Consolidated Edison Co. of New York, Inc.	59 / 81
<b>Filing Information</b>		Application and Design		Manual No. 4	

Paper copies of procedures and instructions are uncontrolled and therefore may be outdated. Please consult Distribution Engineering Intranet Site [Distribution Engineering](#) or <http://distribution>, for the current version prior to use.

operation of either the Utility Ground Switch or the Disconnect Switch.

**9.2.7 Additional Requirements For Ground and Disconnect Switches:**

- 9.2.7.1 Electric interlocks shall be provided to prevent closing of a Ground Switch when the associated Line Switch is closed.
- 9.2.7.2 Electric interlocks shall be provided to prevent closing of the Line Switch when an associated Ground Switch is closed.
- 9.2.7.3 Mechanical or key interlocks shall be provided to permit access to the interior of the Line Switch compartment only when the Line Switch is open.
- 9.2.7.4 Mechanical or key interlocks shall be provided to permit access to the interior of a Ground Switch compartment only when the Ground Switch is closed.
- 9.2.7.5 Barrier panels shall be provided in the Line Switch compartment to minimize the possibility of contact with energized parts when the Line Switch compartment is open.
- 9.2.7.6 KB, KC and KD keys and Line and Ground Switch compartment access keys shall be uniquely keyed to each device and fitted with identifying tags.

**10.0 SWITCHGEAR PROTECTION AND CONTROL EQUIPMENT**

**10.1 Customer Requirements** - The Customer shall furnish, install and maintain all protective relays, voltage transformers and current transformers (except those furnished by the Company for revenue metering), trip/control circuits required for the proper protection and operation of the service equipment and the Company's primary service feeders. The required protection shall be in

Specification	Revision	Rev Date	Effective Date	Copyright Information	Page
EO – 2022	15		12/31/2009	1966-2009 Consolidated Edison Co. of New York, Inc.	60/81
<b>Filing Information</b>		Application and Design		Manual No. 4	

Paper copies of procedures and instructions are uncontrolled and therefore may be outdated. Please consult Distribution Engineering Intranet Site [Distribution Engineering](#) or <http://distribution>, for the current version prior to use.

accordance with the latest IEEE, ANSI, NEMA standards and as generally outlined herein, in the **General Specification** and other Company specifications listed in the reference section (see Section 14.0).

10.2 **Protective Relay Design** – The following are the minimum protective relay requirements for Customer substations. Additional protective relay equipment may be required for specific installations.

10.2.1 **General** – All protective relays shall be utility grade in drawout cases.

10.2.1.2 **Electromechanical relays** shall be equipped with built-in test-plug facilities or equivalent external test switches for testing and calibrating the relays.

10.2.1.3 **Microprocessor-based relays** shall have built-in self-test functions that with an alarm contact that shall be connected to the Customer's substation monitoring system.

10.2.1.4 **Auxiliary relays** in protective relay circuits shall be utility grade with screw terminal connections (plug-in relays are not acceptable).

10.2.1.5 All protective relays shall provide target indication when the associated device is tripped.

10.2.2 **Short Circuit & Coordination Study** – The Customer must submit a Short Circuit & Coordination Study for review and approval. A preliminary study may be prepared in the early design stages so that equipment ratings, instrument transformer ratios and relay types can be specified. The Customer's protective relay system shall be designed to avoid simultaneous tripping of supply feeders for secondary faults. Note: All protection devices shall be properly calibrated and coordinated to ensure a minimum fault clearing time.

10.2.3 **Trip Circuit Monitoring** – Trip circuit monitoring is required for the primary service feeder, main transformer and bus-tie circuit breakers and the associated lockout relays.

Specification	Revision	Rev Date	Effective Date	Copyright Information	Page
EO – 2022	15		12/31/2009	1966-2009 Consolidated Edison Co. of New York, Inc.	61 / 81
<b>Filing Information</b>		Application and Design		Manual No. 4	

Paper copies of procedures and instructions are uncontrolled and therefore may be outdated. Please consult Distribution Engineering Intranet Site [Distribution Engineering](#) or <http://distribution>, for the current version prior to use.

- 10.2.3.1 Trip circuit monitoring shall be equipped with an alarm contact that is connected to the Customer’s substation monitoring system.
- 10.2.3.2 Trip circuit monitoring shall be connected at the end of the trip ladder so that the circuit breaker or lockout relay trip coil and the associated trip circuit wiring is monitored.
- 10.2.3.3 Trip circuit monitoring that is connected to a category alarm shall be designed to prevent masking of the category alarm when the associated circuit breaker is open or in the test or disconnect position or when the associated lockout relay is in the operate position.
- 10.2.4 **VT Secondary** - The VT secondaries shall be non-fused for protective relay connection.
- 10.2.5 **Alarm Monitoring** - All alarm signals shall be transmitted to the Customer’s operating facility that is actively monitored on a 24-hour basis.
- 10.2.6 **Zero Sequence Voltage Protection** – Zero sequence voltage protection is required for all Customers supplied at 33 kV, 27 kV and 13 kV. Refer to paragraph 10.2.9.3 for additional details.
- 10.2.7 **Switch Fuse Installations** – The primary service feeder fuse shall be equipped with open phase protection. Overcurrent protection shall prevent the operation of the associated load-break switch when the current through the switch exceeds its rated interrupt capability.
- 10.2.8 **Radial Installations - Circuit Breaker** – The primary service feeder circuit breaker relay package includes three-phase and ground overcurrent relays. Relays shall trip the associated circuit breaker via a manually reset lockout relay. Overcurrent relays associated with transformer primaries shall be equipped with

Specification	Revision	Rev Date	Effective Date	Copyright Information	Page
EO – 2022	15		12/31/2009	1966-2009 Consolidated Edison Co. of New York, Inc.	62 / 81
<b>Filing Information</b>		Application and Design		Manual No. 4	

Paper copies of procedures and instructions are uncontrolled and therefore may be outdated. Please consult Distribution Engineering Intranet Site [Distribution Engineering](#) or <http://distribution>, for the current version prior to use.

instantaneous elements. We recommend a differential relay package for the power transformers.

10.2.9 **Multiple Feeder Substations** – The protective relay system shall be designed and coordinated so that no single fault will cause an outage of the entire Customer substation or the loss of multiple Company feeders. In addition to the requirements for radial installations, substations supplied by two or more feeders that are operated in parallel by the Customer shall include the following protective relay functions:

10.2.9.1 **Three-phase directional overcurrent relays** (device number 67) that trip the associated circuit breaker directly. The directional overcurrent relays shall trip for current flowing towards the Con Edison system. The directional overcurrent relays shall be set to clear backfeed via the Customer’s substation into multiphase-faults on the Con Edison supply feeders.

10.2.9.2 **Reverse power relay** (device number 32) that trips the associated circuit breaker directly. The reverse power relay shall trip for power flow towards the Con Edison system. The reverse power relay shall be set to clear backfeed via the Customer’s substation to loads connected to the Con Edison supply feeders.

10.2.9.3 **Zero sequence voltage detection** for ungrounded systems (device numbers 27 & 59) that trip the associated circuit breaker directly. These relays shall be supplied from:

- A phase-to-ground connected VT located on the load side of the primary service feeder circuit breaker or
- A phase-to-ground connected coupling capacitor potential device (CCPD) located on the line side of the Customer’s primary service feeder circuit breaker.

Specification	Revision	Rev Date	Effective Date	Copyright Information	Page
EO – 2022	15		12/31/2009	1966-2009 Consolidated Edison Co. of New York, Inc.	63 / 81
<b>Filing Information</b>		Application and Design		Manual No. 4	

Paper copies of procedures and instructions are uncontrolled and therefore may be outdated. Please consult Distribution Engineering Intranet Site [Distribution Engineering](#) or <http://distribution>, for the current version prior to use.

**Note:** all equipment connected to the line side of the main primary service feeder circuit breaker must be able to withstand Con Edison periodic feeder hi-pot testing. Drawing No. 1 is a conceptual example of the scheme connected to a load-side phase-to-ground VT.

- 10.2.9.4 **Transformer main circuit breakers** shall be equipped with three phase overcurrent relays that trip the associated circuit breaker via a manually reset lockout relay.
- 10.2.9.5 **Transformer differential protection** is recommended for all transformers with a base rating greater than 2500 kVA. The Company for specific Customer installations may require the installation of transformer differential protection. Transformer differential relays shall trip the associated primary and secondary circuit breakers via a dedicated lockout relay.
- 10.2.9.6 **Transformer neutral overcurrent** relays are recommended. The Company for specific Customer installations may require the installation of transformer neutral overcurrent relays. Transformer neutral overcurrent relays shall trip via a lockout relay.
- 10.2.9.7 **Bus tie circuit breakers** require automatic tripping via lockout relays.
- 10.2.9.8 **Bus differential protection** is recommended for the transformer secondary buses. The Company for specific Customer installations may require the installation of bus differential protection.
- 10.2.9.9 **Overcurrent protection** is recommended for the bus tie circuit breakers and/or the transformer secondary buses. The Company for specific Customer installations may require the installation of overcurrent protection.

Specification	Revision	Rev Date	Effective Date	Copyright Information	Page
EO – 2022	15		12/31/2009	1966-2009 Consolidated Edison Co. of New York, Inc.	64 / 81
<b>Filing Information</b>		Application and Design		Manual No. 4	

Paper copies of procedures and instructions are uncontrolled and therefore may be outdated. Please consult Distribution Engineering Intranet Site [Distribution Engineering](#) or <http://distribution>, for the current version prior to use.



10.2.9.10 For installations whose design is based of synchronizing buses, reactor buses, etc., the protection requirements for transformer buses and bus tie circuit breakers shall apply.

---

<b>Specification</b>	<b>Revision</b>	<b>Rev Date</b>	<b>Effective Date</b>	<b>Copyright Information</b>	<b>Page</b>
EO – 2022	15		12/31/2009	1966-2009 Consolidated Edison Co. of New York, Inc.	65/81
<b>Filing Information</b>		Application and Design		Manual No. 4	

Paper copies of procedures and instructions are uncontrolled and therefore may be outdated. Please consult Distribution Engineering Intranet Site [Distribution Engineering](#) or <http://distribution>, for the current version prior to use.

# Drawing No. 1: Example of under/overvoltage protection for supply side ground faults

## DC Schematic

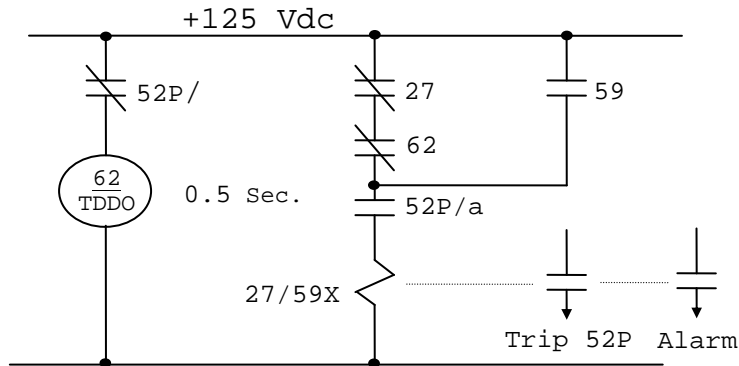

## One Line Diagram

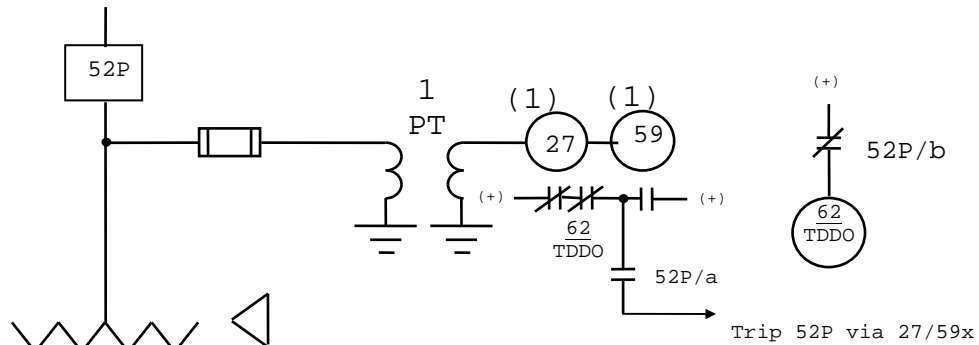

### Recommended relays or equivalent.

- 27 = G.E. 12IAV54E14A (32-80V)
- 59 = G.E. 12IAV51A1A (55-140V)

Supply Voltage	PT Rating	Secondary Voltage	UV (27) Setting	OV (59) Setting
33 kV	34500/115	63.5 V	41 V D.O. T.D. #2	82 V P.U. T.D.#2
26.4 kV	34500/115	50.8 V	32 V D.O. T.D. #2	61 V P.U. T.D. #2
13.2-13.8 kV	14400/120	63.5-66.4 V	41 V D.O. T.D. #2	82 V P.U. T.D.#2

To  
Customer  
Equipment

Specification	Revision	Rev Date	Effective Date	Copyright Information	Page
EO - 2022	15		12/31/2009	1966-2009 Consolidated Edison Co. of New York, Inc.	66/81
<b>Filing Information</b>		Application and Design		Manual No. 4	

Paper copies of procedures and instructions are uncontrolled and therefore may be outdated. Please consult Distribution Engineering Intranet Site [Distribution Engineering](#) or <http://distribution>, for the current version prior to use.

10.3 **Voltage and Current Transformers** - Customer's voltage and current transformers shall be selected with an insulation rating to withstand the same dielectric proof test described in the section designated Proof Tests Section 13.0.

10.4 **Voltage Transformer Accuracy Class** - All instrument voltage transformers shall have a nominal voltage accuracy class as listed below:

Nominal Voltage (kV)	Rated Voltage (kV)	Class	Transformer BIL (KV)	Ratio
4	5.0	1.2 z	60	35:1
13	15.0	0.6 z	95	110:1
27	38.0	0.3 z	200	220:1
33	38.0	0.3 z	200	300:1

10.5 **Current Transformer Accuracy Class** - The relaying accuracy class of current transformers shall be sufficient to ensure proper operation and coordination of the associated protective relays for all fault conditions. Current transformers shall not saturate for the maximum available fault current that passes through the CT and the actual CT secondary burden.

10.6 **Current Transformer Short-Time Current Values** - All current transformers shall be selected to meet or exceed the following short-time RMS current values:

Specification	Revision	Rev Date	Effective Date	Copyright Information	Page
EO – 2022	15		12/31/2009	1966-2009 Consolidated Edison Co. of New York, Inc.	67/81
<b>Filing Information</b>		Application and Design		Manual No. 4	

Paper copies of procedures and instructions are uncontrolled and therefore may be outdated. Please consult Distribution Engineering Intranet Site [Distribution Engineering](#) or <http://distribution>, for the current version prior to use.

Nominal Voltage (kV)	Rated Voltage (kV)	Rated Current Mechanical	Rated Current Thermal
4	5.0	56.0	35.0
13	15.0	71.0	45.0
26	38.0	56.0	35.0
33	38.0	56.0	35.0

- 10.7 **Ground Wiring Connection** - Current and voltage transformer secondary windings shall be grounded with a copper conductor not smaller than #10 AWG and connected to a ground bus located as closely as possible to the transformers.
- 10.8 **Test Facilities** - The Customer shall provide suitable facilities for testing relays; including a convenient outlet of 120 volts AC, test studs and links for each relay.
- 10.9 **DC Power System** - All relay protection and control circuits shall be supplied from a 125 Volt DC power system (capacitor trip devices are not acceptable). Radial service installations require only one battery system. Parallel service installations require two independent battery systems. Personnel shall be protected from accidental contact with live parts by approved enclosures (Reference: NEC Code requirements provided in Section 110-17 and Article 480).
- 10.9.1 **The Battery Room**
- 10.9.1.1 The 125VDC batteries shall be installed in a properly ventilated battery room, which conforms to local codes.
- 10.9.1.2 The walls in the battery room walls shall not be painted.
- 10.9.1.3 The floors shall be concrete and have an un-coated finish.
- 10.9.1.4 The battery rooms shall be heated and ventilated.

Specification	Revision	Rev Date	Effective Date	Copyright Information	Page
EO – 2022	15		12/31/2009	1966-2009 Consolidated Edison Co. of New York, Inc.	68/81
<b>Filing Information</b>		Application and Design		Manual No. 4	

Paper copies of procedures and instructions are uncontrolled and therefore may be outdated. Please consult Distribution Engineering Intranet Site [Distribution Engineering](#) or <http://distribution>, for the current version prior to use.

- 10.9.1.5 The battery rooms shall be separated.
- 10.9.1.6 The light switches and receptacles in the battery room shall be made of explosion proof materials.
- 10.9.1.7 The light fixtures shall not be located directly over the battery racks.
- 10.9.1.8 Spill containment shall be provided on the floor under the battery racks.
- 10.9.1.9 The batteries shall be mounted in a single row or a two-tier rack. Racks shall be epoxy-coated steel and shall be solidly grounded to the station ground.
- 10.9.1.10 The exterior door of each battery room shall have a sign that identifies the room (example: 125VDC Battery Room No.1).
- 10.9.1.11 The rectifier, the DC panel and transfer switches shall be located outside the battery room.
- 10.9.1.12 It is recommended that an eye wash station be installed outside the battery rooms.

## 10.9.2 The Battery System

- 10.9.2.1 A Radial supply battery system shall consist of a rectifier, 125VDC batteries, a battery disconnect switch and a DC panel.
- 10.9.2.2 A Parallel supply battery system consists of two AC automatic transfer switches, two rectifiers, two 125VDC batteries, two DC non-fused three-pole battery disconnect switches, two DC automatic transfer switches and two DC panels.

Specification	Revision	Rev Date	Effective Date	Copyright Information	Page
EO – 2022	15		12/31/2009	1966-2009 Consolidated Edison Co. of New York, Inc.	69 / 81
<b>Filing Information</b>		Application and Design		Manual No. 4	

Paper copies of procedures and instructions are uncontrolled and therefore may be outdated. Please consult Distribution Engineering Intranet Site [Distribution Engineering](#) or <http://distribution>, for the current version prior to use.

- 10.9.2.3 The three phase, 208VAC supply to the AC automatic transfer switches shall be supplied from separate AC sources.
- 10.9.2.4 The two independent DC systems shall not be tied together under any situation. Transfer shall be set to occur whenever the normal supply drops below 90% of rated voltage.
- 10.9.2.5 A ground detection device shall be installed on each DC system.
- 10.9.2.6 The rectifiers shall be furnished with failure alarms to indicate low voltage and ground. The failure alarms shall be sent to the station alarm annunciator panel that shall be monitored on a continuous basis. The rectifiers shall be equipped with DC ammeters and voltmeters. It shall be noted that on rare occasions the rectifiers may be required to supply the dc panel without the batteries connected.
- 10.9.2.7 Each of the rectifiers shall have sufficient capacity to supply the total station steady state DC load, plus the power required to charge a discharged battery from 1.75 volts per cell to 2.33 volts per cell at the maximum charge rate, plus a spare capacity of 15%.
- 10.9.2.8 The desirable continuous current output rating of the rectifier shall not exceed 25% of the 8-hour ampere rating of the battery.
- 10.9.2.9 The rectifiers shall have sufficient capacity to simultaneously trip the single fault maximum number of circuit breakers in the substation with the ac and dc transfer switches in the normal position.
- 10.9.2.10 Batteries shall be rated on the DC load profile with their ability to supply a constant DC current for eight hours.

Specification	Revision	Rev Date	Effective Date	Copyright Information	Page
EO – 2022	15		12/31/2009	1966-2009 Consolidated Edison Co. of New York, Inc.	70 / 81
<b>Filing Information</b>		Application and Design		Manual No. 4	

Paper copies of procedures and instructions are uncontrolled and therefore may be outdated. Please consult Distribution Engineering Intranet Site [Distribution Engineering](#) or <http://distribution>, for the current version prior to use.

- 10.9.2.11 The batteries shall have sufficient capacity to simultaneously trip and then operate the spring charging motors for a single fault maximum number of circuit breakers in the substation with a single battery in service while carrying the substation steady state dc load without the aid of the battery chargers.
- 10.9.2.12 The three pole DC disconnect switches shall have an auxiliary contact connected to an alarm contact. The alarm shall monitor the open DC disconnect switch.
- 10.9.2.13 The battery supply leads shall have the positive (+) cable leg and negative (-) cable leg installed in separate non-metallic conduits (note: PVC should only be considered for below grade installation).
- 10.9.2.14 The DC load shall be equally divided for two battery systems. Diversity shall be maintained for the DC distribution system. For example, adjacent bus section shall be supplied from different batteries.
- 10.9.2.14 Separate fusing shall be provided for circuit breaker trip circuits, closing circuits and for each lockout relay trip circuit.

11.0 **POWER TRANSFORMERS**

- 11.1 **Acceptable Power Transformers** - The Customer shall furnish, install and maintain all service power transformers. Service power transformers shall be conform to the latest applicable IEEE, ANSI, and Company standards as stated herein.
- 11.2 **Connections** - Service power transformers for all primary voltages shall be connected delta primary and grounded wye secondary (solid grounding is strongly recommended). As an exception, Customers using a 4 kV primary transformer connection shall consult with the Company as to the recommended transformer connection. Customers supplied by the Company from auto-loop feeders shall consult with the Company for the power transformer connection required.

Specification	Revision	Rev Date	Effective Date	Copyright Information	Page
EO – 2022	15		12/31/2009	1966-2009 Consolidated Edison Co. of New York, Inc.	71 / 81
<b>Filing Information</b>		Application and Design		Manual No. 4	

Paper copies of procedures and instructions are uncontrolled and therefore may be outdated. Please consult Distribution Engineering Intranet Site [Distribution Engineering](#) or <http://distribution>, for the current version prior to use.

11.3 **BIL Requirements** - The primary and secondary Basic Insulation Levels (BIL) of all power transformers shall be equal or exceed the ratings shown below:

Nominal Voltage (kV)	Required BIL (kV)
Less than 4	As per ANSI
4	60
13	95
27	150
33	200*

\* A Company variance is required to use 150 kV BIL @ 33kV

11.4 **Automatic Tap Changers** - When automatic tap changer equipment is used, it is recommended that the Customer disconnect the automatic circuit when the primary service feeder breaker is open to prevent erratic tap changer operations.

## 12.0 **EQUIPMENT AND FEEDER MARKINGS**

12.1 **Nameplates and Labeling** - All equipment (transformers, switchgear, etc.) shall be furnished with permanent type of nameplates located on the equipment in a convenient location for identification. The designations to be permanently inscribed on the nameplates and shall be as shown on the approved one line diagrams and equipment drawings. All switchgear control & protective relaying and meter devices, which are located on the cubicle doors or mimic panels shall be labeled with the specific device number.

12.2 **Phase Markings** - All terminations shall be labeled and marked in a permanent manner with an appropriate code. Disconnecting switches, terminations and other equipment on three-phase services shall be marked to identify the phases properly. The first termination bus on the primary

Specification	Revision	Rev Date	Effective Date	Copyright Information	Page
EO – 2022	15		12/31/2009	1966-2009 Consolidated Edison Co. of New York, Inc.	72/81
<b>Filing Information</b>		Application and Design		Manual No. 4	

Paper copies of procedures and instructions are uncontrolled and therefore may be outdated. Please consult Distribution Engineering Intranet Site [Distribution Engineering](#) or <http://distribution>, for the current version prior to use.



service should be so connected that the phase designations are A-B-C when facing the front of the switchgear and reading from left to right.

- 12.3 **Terminal Blocks and Wire Markings** - To facilitate maintenance and installation, all control, alarm and protective relaying wiring and terminal strips shall be marked with permanent type markers in accordance with wire and terminal block designations as shall be noted on the wiring diagrams. See MES-350 for Revenue Metering wiring requirements.

13.0 **PROOF TESTS**

- 13.1 **Primary Service Feeder Cable, Bus Potheads and Equipment** - The Company and Customer's primary service feeder cable shall be tested, from time to time, at the voltage and duration values stated in latest revision of Company specification EO-4019. During the proof test the circuit breaker will be racked-out or disconnect switch will be opened to isolate the Customer's equipment; however, any Customer equipment connected on the line side of the circuit breaker or disconnect switch will be subjected to the Company's proof testing values as stated in EO-4019. The Customer's potential transformers or other equipment will not be disconnected prior to the test and therefore shall be sized to meet the Company's proof test values. The proof test shall be witnessed by the Company's Field Engineer.

- 13.2 **Customer Cable and Switchgear** - The Customer shall perform and submit to the Company for record, results of cable, switchgear and equipment Proof Tests, performed at the site, for all equipment connected after primary service feeder potheads. Proof tests shall be in accordance with the latest IEEE (ANSI) standards and manufacturer's recommendations. At the Customers request, the Company will recommend proof test values; however, Company's proof test values are usually more stringent than the manufacturer's recommendations. Proof test are required for:

13.2.1 All new installations.

13.2.2 After a service or proof test failure resulting from a fault on the Customer's installation.

Specification	Revision	Rev Date	Effective Date	Copyright Information	Page
EO – 2022	15		12/31/2009	1966-2009 Consolidated Edison Co. of New York, Inc.	73 / 81
<b>Filing Information</b>		Application and Design		Manual No. 4	

Paper copies of procedures and instructions are uncontrolled and therefore may be outdated. Please consult Distribution Engineering Intranet Site [Distribution Engineering](#) or <http://distribution>, for the current version prior to use.

- 13.2.3 Before re-energizing cable or equipment which has not been in service for one year or longer.
  - 13.2.4 After upgrading or adding new or spare equipment, enclosed wiring, or other work disturbing the insulation of the existing equipment or wiring.
  - 13.2.5 After work which involves removal of tanks or equipment access covers.
- 13.3 **Power Transformers** - Customer's power transformers shall be subject to a high potential proof test at the project site. The power transformer manufacturer's recommended values shall be used for the proof tests.

14.0 **APPROVAL OF PROJECT DRAWINGS AND DOCUMENTS**

- 14.1 **Review Items: Initial Project Stage** - The Customer is required to submit for Company record, review and approval, at the beginning stage of the project, the following:
- 14.1.1 A signed copy of the General Requirements for Service to High Tension Customers ... EO-2022 General Revision12.
  - 14.1.2 A signed copy of the High Tension Technical Specification (DE Specification No. assigned by Customer Service) based on EO-2022, Technical Revision 13.
  - 14.1.3 Six copies of a site specific (not typical), **Engineering Consultant's One Line Diagram**, which shall include Project Name & Location in the Title Box, date and revision number, approval signature and shall show quantity of each item, where more than one item is supplied. The One Line diagram shall be based on the American Society of Mechanical Engineers Electrical and Electronic

Specification	Revision	Rev Date	Effective Date	Copyright Information	Page
EO – 2022	15		12/31/2009	1966-2009 Consolidated Edison Co. of New York, Inc.	74 / 81
<b>Filing Information</b>		Application and Design		Manual No. 4	

Paper copies of procedures and instructions are uncontrolled and therefore may be outdated. Please consult Distribution Engineering Intranet Site [Distribution Engineering](#) or <http://distribution>, for the current version prior to use.

Diagrams drafting practices - USAS Y14.15 - 1966 and the supplement Y14.15a - 1971 and shall include the following:

- a. Power Transformers (primary and secondary voltage, power rating, impedance and phasor diagram)
- b. Voltage & Current Transformers (connections and ratios)
- c. Circuit Breakers and Loadbreak Disconnect Switches (continuous current, symmetrical MVA ratings, and status - (N.O./N.C.)
- d. Fuses and their ratings
- e. Revenue Metering Transformers and Phasing Receptacles
- f. Surge Arrester Characteristics, Control Switches, Neon indicators and Voltage and Current Instruments
- g. Bus and Cable ratings
- h. Grounding Devices and Ground Studs
- i. Relaying (device No. and tripping direction) and shall show the full contact development.
- j. Interlocking (mechanical & electrical)
- k. Generators (type, use, size, connections and impedances)
- l. Customer feeder destinations and Special Operating Details including ATS logic and signal direction.

14.2 **Review Items: Design Stage** - During the design stage of the project the Customer shall submit the following:

Specification	Revision	Rev Date	Effective Date	Copyright Information	Page
EO – 2022	15		12/31/2009	1966-2009 Consolidated Edison Co. of New York, Inc.	75 / 81
<b>Filing Information</b>		Application and Design		Manual No. 4	

Paper copies of procedures and instructions are uncontrolled and therefore may be outdated. Please consult Distribution Engineering Intranet Site [Distribution Engineering](#) or <http://distribution>, for the current version prior to use.

- 14.2.1 A revised One Line diagram which shall include comments made on the initial submittal.
- 14.2.2 A.C./D.C. schematic diagrams of the protection and control circuits.
- 14.2.3 Bill of Materials - including all relays, voltage & current transformers (showing ratios and connections) fuses and interrupting & grounding devices
- 14.2.4 A relay coordination study and proposed protective relay settings.
- 14.2.5 Metering compartment equipment showing the physical layout & clearances, barriers and phasing facilities.
- 14.2.6 Bus, Cables & Terminations; (manufacturer's specifications).
- 14.2.7 Ground & Test Devices and Ground Switches; manufacturer, detailed description of operation, equipment drawings, specifications and interlocks.
- 14.2.8 Equipment room layouts (detailing all clearances) and the site plans.
- 14.2.9 DC system One Line diagrams, detailing the battery and charger types, distribution panels, transfer switches, relaying and alarms.
- 14.2.10 Vendor drawings, specifications and Vendor documentation shall be reviewed by the Customer prior to submittal to the Company.
- 14.2.11 Emergency Generator; interlocking procedures, load to be supplied and testing schedule.

14.3 **Review Items: Prior to Energization** - Prior to energization the Customer shall resubmit all drawings corrected and marked FINAL and stamped by a Professional Engineer for Company record. The project site will be inspected by Company personnel, from time to time, to verify compliance with Company

Specification	Revision	Rev Date	Effective Date	Copyright Information	Page
EO – 2022	15		12/31/2009	1966-2009 Consolidated Edison Co. of New York, Inc.	76 / 81
<b>Filing Information</b>		Application and Design		Manual No. 4	

Paper copies of procedures and instructions are uncontrolled and therefore may be outdated. Please consult Distribution Engineering Intranet Site [Distribution Engineering](#) or <http://distribution>, for the current version prior to use.

specifications. The Customer shall also submit for review and approval the following:

- 14.3.1 Certified relay test data including the date of test and all voltage and current transformer ratios.
- 14.3.2 An Operating Specification which shall detail all operations under normal and contingency modes of operations.
- 14.3.3 Certified Customer equipment High Potential Proof Test data and equipment operation test results. Operation tests shall include all interrupting and grounding devices and the successful operation shall be witnessed by the Company's Field Engineering Representative.
- 14.3.4 The Company will verify that the Customer's equipment nameplates and phase markings are as noted on the Customer's drawings.
- 14.3.5 The Company will verify that a laminated copy of the approved/final one line diagram and UC drawing is posted in the appropriate location(s).
- 14.3.6 The Company will verify that the Key storage lock box is on site.
- 14.3.7 The Company will verify that the Grounding device, tripping operation, interlocking system is functioning as required.
- 14.3.8 The Customer shall have the conduits or building attachments completed and in place to accept the telephone service.
- 14.3.9 The Company will verify if Revenue Metering system is in place and ready for operation.

14.4 **Energization** - Energization will be permitted only after the successful completion of all Company and Customer specification requirements and a finalized Customer written/Company approved **System Operation Specification** is accepted. The System Operation Specification shall include all normal and contingency modes of operation, including which switches are

Specification	Revision	Rev Date	Effective Date	Copyright Information	Page
EO – 2022	15		12/31/2009	1966-2009 Consolidated Edison Co. of New York, Inc.	77 / 81
<b>Filing Information</b>		Application and Design		Manual No. 4	

Paper copies of procedures and instructions are uncontrolled and therefore may be outdated. Please consult Distribution Engineering Intranet Site [Distribution Engineering](#) or <http://distribution>, for the current version prior to use.

open and closed and which indicating lights will be on or off. The System Operation Specification shall include but not limited to:

- Planned Outages on a primary service feeder.
- Fault on the line side of a primary service feeder.
- Fault on the load side of a primary service feeder.

The Customer shall submit all finalized documents including **as built** drawings. The Company will perform the required proof test on the primary service feeders up to and including the Customer's feeder terminations (see Proof Test Section 13.0).

## 15.0 LIST OF COMPANY REFERENCES

<a href="#">EO-2012</a>	Application of Lightning Arresters on Overhead Distribution Systems - Manual 4
<a href="#">EO-2034</a>	Electric and Gas Services to DC Railroad Properties - Manual 4
<a href="#">EO-2034</a>	Closed Transition Transfer From and To Con Edison's Supply
<a href="#">EO-4019</a>	Proof Testing and Ammeter Clear Testing of Feeders and Feeder Mains - Manual 5
<a href="#">EO-4035</a>	Operation and Maintenance of Equipment on High Tension Customer's Premises - Manual 5
<a href="#">EO-6025</a>	Cable Arcproofing Procedures - Manual 3
<a href="#">EO-6224</a>	Requirements for Installing Direct Buried Cable in Both Public and Private Streets - Manual 3
<a href="#">EO-2468-B</a>	Cable Manhole Drawing - Manual 3
<a href="#">EO-3299-D</a>	Low Voltage Phasing Facilities Drawing for Three Phase, Three Wire High Tension Feeders - Manual 5

Specification	Revision	Rev Date	Effective Date	Copyright Information	Page
EO – 2022	15		12/31/2009	1966-2009 Consolidated Edison Co. of New York, Inc.	78 / 81
<b>Filing Information</b>		Application and Design		Manual No. 4	

Paper copies of procedures and instructions are uncontrolled and therefore may be outdated. Please consult Distribution Engineering Intranet Site [Distribution Engineering](#) or <http://distribution>, for the current version prior to use.

[EO-3477-D](#) Low Voltage Phasing Facilities Drawing for Three Phase, Four Wire High Tension Feeders - Manual 5

[EO-6130-C](#) Cable Duct for Manhole Entrance Drawing, P/O EO-1042 - Manual 6

[EO-F3079-C](#) Neon Tube Installation Drawing for Bus Type - Manual 5

[EO-F3782-C](#) Low Voltage Phasing Facilities Drawing for Three Phase, Four Wire High Tension Feeders when Two Voltage Transformers are used - Manual 5

[MES-350](#) High Tension Metering Installations

[MES-273-A](#) Wiring Diagram for 13 kV Metering

[MES-273-B](#) Wiring Diagram for 27 kV & 33 kV Metering

[MES-166-A](#) Wiring Diagram for 2.4/4kV 3 phase 4 wire Metering

[MES-731](#) and 731-A Layout and Wiring for Demand Recorder Metering

[MES-712](#) and 712-A Layout and Wiring for Panel Mount HT Metering with Network Low Tension Auxiliary

[MES-713](#) and 713-A Layout and Wiring for Panel Mount HT Metering with Radial Low Tension Auxiliary

The Company's "General Instructions Governing Work on System Electrical Equipment."

The Company's Blue Book - Requirements for Electric Service Installations

Specification	Revision	Rev Date	Effective Date	Copyright Information	Page
EO – 2022	15		12/31/2009	1966-2009 Consolidated Edison Co. of New York, Inc.	79 / 81
<b>Filing Information</b>		Application and Design		Manual No. 4	

Paper copies of procedures and instructions are uncontrolled and therefore may be outdated. Please consult Distribution Engineering Intranet Site [Distribution Engineering](#) or <http://distribution>, for the current version prior to use.

## 17.0 **CHECKLIST A**

### **Customer's Information**

Customer's Name: \_\_\_\_\_

Customer's Address: \_\_\_\_\_

\_\_\_\_\_

DE Specification Number assigned \_\_\_\_\_ Project Engineer assigned \_\_\_\_\_

Proposed Customer's Service Date \_\_\_ / \_\_\_ / \_\_\_ Service Voltage \_ kV

Number of feeders \_\_\_ initially \_\_\_ ultimately

Customer Loads \_\_\_ initially \_\_\_ ultimately

### **Type of Customer system:**

Radial \_\_\_\_\_ Load side Parallel \_\_\_\_\_ Autotransfer

Emergency Generators \_\_\_ No. \_\_\_ Total MW Capacity

Company Supply Station \_\_\_\_\_

### **Feeder Numbers and Impedance in OHMS:**

Feeder No. \_\_\_\_\_ Impedance \_\_\_ R \_\_\_ X (Normal)

Feeder No. \_\_\_\_\_ Impedance \_\_\_ R \_\_\_ X (Alternate)

Feeder No. \_\_\_\_\_ Impedance \_\_\_ R \_\_\_ X

Feeder No. \_\_\_\_\_ Impedance \_\_\_ R \_\_\_ X

Feeder No. \_\_\_\_\_ Impedance \_\_\_ R \_\_\_ X

### **Please Include:**

Customer's one line diagram

Service Information Request (SIR)

Specification	Revision	Rev Date	Effective Date	Copyright Information	Page
EO - 2022	15		12/31/2009	1966-2009 Consolidated Edison Co. of New York, Inc.	80 / 81
<b>Filing Information</b>		Application and Design		Manual No. 4	

Paper copies of procedures and instructions are uncontrolled and therefore may be outdated. Please consult Distribution Engineering Intranet Site [Distribution Engineering](#) or <http://distribution>, for the current version prior to use.



18.0 **CONTRACT ACCEPTANCE**

Customer Specification No. DE.....

Service Location: .....  
.....  
.....

Consolidated Edison Company of New York Inc.

Date .....

Company representative.....

Title .....

Customer contract acceptance

Date .....

Customer duly authorized representative: .....

Title .....

Specification	Revision	Rev Date	Effective Date	Copyright Information	Page
EO – 2022	15		12/31/2009	1966-2009 Consolidated Edison Co. of New York, Inc.	81 / 81
<b>Filing Information</b>		Application and Design		Manual No. 4	

Paper copies of procedures and instructions are uncontrolled and therefore may be outdated. Please consult Distribution Engineering Intranet Site [Distribution Engineering](#) or <http://distribution>, for the current version prior to use.