

## **Section VII**

### **ADEQUACY AND SAFETY OF INSTALLATION**

**1. Adequacy and Safety:**

Con Edison is not required to supply gas service until the customer's installation has been approved by the authorities having jurisdiction over the same; and Con Edison further reserves the right to withhold its service, or discontinue its service, whenever such installation or part thereof is deemed by Con Edison to be unsafe, inadequate or unsuitable for receiving Con Edison service, or to interfere with or impair the continuity or quality of the Con Edison's service to the customer or to others.

**2. Repairs-Leakage of Gas:**

All repairs to the customer's piping and equipment will be made by the customer. The Con Edison will, however, maintain gas service piping and meter equipment for 1-2-3 family homes when the meters are outdoors. When the meters are indoors for 1-2-3 family homes, Con Edison will maintain service to the first fitting inside the building.

**3. Repairs, Stoppages, or Pressure Testing:**

When air or gas under pressure is used to clear stoppages or make pressure tests on customer piping, the customer shall physically disconnect his piping to avoid applying pressure to Con Edison's meters, regulators, or mains. Oxygen or combustible gas shall not be used by the customer to clear stoppage or perform pressure tests.

**4. Back-Pressure and Suction:**

a. Scope

When the nature of the customer's utilization equipment may induce back-pressure or suction in the piping system carrying Con Edison's gas, suitable protective devices approved by Con Edison will be installed and maintained by the customer.

b. Where Protection is Required

Protection is required whenever an installation uses pressurized air or oxygen that might accidentally or otherwise cause air or oxygen to enter the gas piping..

Whenever air or oxygen is mixed with gas, and the mixing takes place in the usual enclosed type-mixing tee before the burner nozzle, a check valve is required. The check valve must be installed and maintained by the customer/contractor (See Table XVIII). They are to be visible, accessible and located downstream of the meter and as close to the utilization equipment as practical. Torches must have flame arrestors installed in their supply lines. Customer/contractor is to contact Con Edison when this application is to be used.

c. Gas Pressure Booster Capable of Developing Elevated Pressure Above Minimum Required 4-inch Water Column or More

Excessive suction may be produced if positive displacement type boosters, piston type pumps or centrifugal fan type boosters, which are capable of developing pressure 4-inch water column or more, are started with the meter inlet or service valve closed or restricted. In such installations check valves and a low-pressure electrical switch, which will stop the pump or booster, shall be installed. (Refer to G-2040-9 for installation).



**LAST REVIEW DATE:**  
6/22/11

**REVIEW CYCLE:**  
5 Years

**SPECIFICATION:**                    **G-2040-9**

**TITLE:**                                **REQUIREMENTS FOR THE INSTALLATION OF  
GAS BOOSTERS, MICROTURBINES AND  
ASSOCIATED SYSTEM PROTECTIVE DEVICES**

**VOLUME:**                            **4 and Gas Blue Book**

**REVISIONS: (See ★)**

- 1) Section 2.0 - Changed "Local Building Code – NYC Department of Buildings" to "New York City Fuel Gas Code."
- 2) Section 3.0 - Added Gas Engineering – New Business.
- 3) Section 4.1 - Reworded for clarity.
- 4) Section 4.2 - Reworded for clarity.
- 5) Section 4.3 - Clarified Gas Engineering to be "Gas Engineering – New Business"
- 6) Section 5.1 - Deleted repetitive wording regarding testing laboratories.
- 7) Section 5.2 - Reformatted. Added reference to magnetic-coupled type boosters. Clarified when explosion-proof motors are required.
- 8) Section 5.3 - New section covering acceptable locations. Renumbered subsequent sections.
- 9) Section 5.4 - Added reference to stainless steel braided hose connections.
- 10) Section 5.5 (A) - Added requirement for check valve to be Con Edison approved.
- 11) Section 5.5 (B)(1) - Added requirement for pressure switch to be Con Edison approved.
- 12) Section 5.5 (B)(2) - Added paragraph covering alternate location of low pressure gas switch. Renumbered subsequent paragraph.

(Continued)

- 13) Section 5.5 (C) - Reworded. Deleted "mercury-free" verbiage.
- 14) Section 5.10 (B)(1) - Added requirement for the one-line drawing to specify the size and location of all piping, the type of connection and the size and configuration of bypass piping. Added note regarding alternate location of low pressure gas switch.
- 15) Section 5.11 - Revised section title in (A). Reworded (A) and (B) for clarity.
- 16) Section 6.0 - Clarified requirements when microturbines are installed.
- 17) Section 7.0 - Updated "References" section.
- 18) Section 8.0 - Updated to reflect revised title of Appendix B
- 19) Appendix A - Reformatted item 1. Added (B). Added area for "Additional Info"
- 20) Appendix B - Revised title. Reformatted Field Verification Check List and reworded items 5, 8 and 9 for clarity.
- 21) Dwg #311296 - Added flex connector and Note 5.



# Gas Operations Standards

---

**TITLE: REQUIREMENTS FOR THE  
INSTALLATION OF GAS BOOSTERS,  
MICROTURBINES AND ASSOCIATED  
SYSTEM PROTECTIVE DEVICES**

---

## TABLE OF CONTENTS

<u>SECTION</u>	<u>TITLE</u>	<u>PAGE</u>
1.0	SCOPE	2
2.0	LEGAL REQUIREMENTS	2
3.0	ORGANIZATIONS APPLICABLE	2
4.0	RESPONSIBILITIES	2
5.0	GAS BOOSTER INSTALLATIONS	2
6.0	MICROTURBINE INSTALLATIONS	7
7.0	REFERENCES	7
8.0	ATTACHMENTS	7

<b>ENVIRONMENTAL REVIEW BY: A. Liguori</b>		<b>SAFETY REVIEW BY: A. Liguori</b>		
<b>PREPARED BY:</b>	<b>APPROVED BY:</b>	<b>DATE:</b>	<b>VOLUME: 4 and Gas Blue Book</b>	<b>PAGE 1 OF</b>
<b>S. Yapchanyk</b>	<b>Frank Ciminiello Chief Gas Distribution Engineer</b>	<b>6/22/11</b>	<b>Application and Design; Gas Blue Book</b>	<b>7 PAGES</b>



**TITLE: REQUIREMENTS FOR THE  
INSTALLATION OF GAS BOOSTERS,  
MICROTURBINES AND ASSOCIATED  
SYSTEM PROTECTIVE DEVICES**

1.0 **SCOPE**

This specification covers the requirements for the installation of gas boosters, microturbines and associated system protective devices to be installed by the customer.

★ 2.0 **LEGAL REQUIREMENTS**

New York City Fuel Gas Code, NYC Department of Buildings and in Westchester County the municipality having jurisdiction.

Other Codes (as they apply).

★ 3.0 **ORGANIZATIONS APPLICABLE**

Westchester, Manhattan, Bronx and Queens Gas Operations; Gas Engineering – New Business; Energy Services.

4.0 **RESPONSIBILITIES**

★ 4.1 The Energy Services Representative shall indicate on the electronic Service Determination Request in Logica/work management system, each item of customer utilization equipment that will require gas pressure in excess of 4 inches water column (w.c.).

★ 4.2 Energy Services shall be responsible for performing field checks of the booster installation and completing Appendix B.

★ 4.3 Gas Engineering – New Business shall determine the service size.

4.4 The customer, the customer's engineer or customer's contractor shall be responsible to have the booster manufacturer's representative prepare the submittals indicated in Section 5.9 of this specification.

5.0 **GAS BOOSTER INSTALLATIONS**

★ 5.1 Con Edison is required to supply a minimum gas pressure of 4 inches w.c. at the head of service. A gas booster may be installed by the customer when Con Edison-supplied gas pressure is not sufficient to supply new gas



<b>NUMBER:</b>	<b>DATE:</b>	<b>VOLUME: 4 and Gas Blue Book</b>	<b>PAGE 2</b>
<b>G-2040-9</b>	<b>6/22/11</b>	<b>Application and Design; Gas Blue Book</b>	<b>OF 7 PAGES</b>



**TITLE: REQUIREMENTS FOR THE  
INSTALLATION OF GAS BOOSTERS,  
MICROTURBINES AND ASSOCIATED  
SYSTEM PROTECTIVE DEVICES**

5.0 **GAS BOOSTER INSTALLATIONS** (Continued)

utilization equipment. Only gas boosters listed by a nationally recognized testing laboratory (i.e., UL or CSA) shall be used with natural gas.

- ★ 5.2 A) For **indoor installations**, the gas booster shall be hermetically-sealed.
  - 1) Where the booster design is of the direct-drive type with motor enclosed within the booster canister, the motor shall be explosion-proof.
  - 2) Where the booster design is of the magnetic-coupled type with an external motor, the motor need not be explosion-proof, unless it will be installed in a NEMA 7 location.
- B) For **outdoor installations**, a non hermetically-sealed booster may be used.

★ 5.3 Acceptable locations for gas boosters shall be determined by local codes and authorities having jurisdiction.

★ 5.4 The gas booster shall be mounted and installed as per the manufacturer's specifications and/or drawings. This may include the installation of stainless steel braided hose connections.

5.5 **Required Protective Equipment**

- ★ A) **Check Valve**

A check valve shall be installed by the customer between the gas meter and the gas booster as shown in drawing 311296, attached. The check valve is required to prevent flow back through the gas meter and into the Con Edison gas distribution system. The booster manufacturer or its authorized representative shall specify the size and minimum distance between the check valve and the booster inlet. This information shall be indicated on Line 16 of Appendix A. See Section 5.10. Only Con Edison-approved check valves shall be used. See Section 5.5 (C).



<b>NUMBER:</b>	<b>DATE:</b>	<b>VOLUME: 4 and Gas Blue Book</b>	<b>PAGE 3</b>
<b>G-2040-9</b>	<b>6/22/11</b>	<b>Application and Design; Gas Blue Book</b>	<b>OF 7 PAGES</b>



**TITLE: REQUIREMENTS FOR THE  
INSTALLATION OF GAS BOOSTERS,  
MICROTURBINES AND ASSOCIATED  
SYSTEM PROTECTIVE DEVICES**

5.0 **GAS BOOSTER INSTALLATIONS** (Continued)

B) Low Pressure Switches

- ★ 1) A low pressure switch with a ¼” diameter manometer test connection (see drawing 311296) shall be installed between the gas meter and the check valve, as close as possible to the gas service point of entry. The switch shall be set and wired to shut the booster off at a minimum of 3 inches w.c. The booster manufacturer or its authorized representative shall specify the make, model and the NEMA rating of the switch on Line 14 of Appendix A. Only Con Edison approved low pressure switches shall be used. See Section 5.5 (C).
  
- ★ 2)
  - a) Where installation of the low pressure gas switch near the gas service point of entry is impractical or prohibitive due to the location of the gas service head valve relative to that of the gas booster, the switch may be installed at an alternate location if approved by the booster manufacturer or authorized representative **and the local Gas Distribution Services (GDS) Department.** See Note in Section 5.10 (B).
  
  - b) If an alternate location is approved, two permanently engraved signs shall be installed: one at the booster, indicating the location of the low pressure gas switch and one at the gas head of service indicating the location of the gas booster and the location of the low pressure gas switch.
  
- 3) A second low pressure switch may be installed on the outlet pipe of the gas booster. This second switch is at the customer’s option and may be used to alarm upon booster failure. This switch need not be a Con Edison-approved switch.
  
- ★ C) Con Edison approved check valves and low pressure switches are listed in Table XVII of Con Edison’s “Requirements for Gas Service Installations” (Gas Blue Book).



NUMBER:	DATE:	VOLUME: 4 and Gas Blue Book	PAGE 4
G-2040-9	6/22/11	Application and Design; Gas Blue Book	OF 7 PAGES



---

---

**TITLE: REQUIREMENTS FOR THE  
INSTALLATION OF GAS BOOSTERS,  
MICROTURBINES AND ASSOCIATED  
SYSTEM PROTECTIVE DEVICES**

---

---

5.0 **GAS BOOSTER INSTALLATIONS** (Continued)

5.6 Branch Supply

Supply of gas to equipment not requiring "boosted pressure" shall be located on the upstream side of the check valve. Branch supply may be connected through the same meter or separate meter(s) depending on the service classifications involved. See drawing 311296-1 attached.

5.7 Piping

Piping from the gas point of entry (POE) to the booster(s) shall be designed by the customer or the customer's authorized representative so as to allow a maximum pressure drop of 1 inch w.c. (excluding the gas meter).

5.8 By-Pass

Some booster installations may require the installation of a by-pass. A by-pass shall be installed when specified by the booster manufacturer or its authorized representative. When required, the by-pass shall be installed downstream of the check valve.

5.9 Re-circulation Loop and Heat Exchanger

Some booster installations may require a re-circulation loop with a heat exchanger and associated sensors and controllers. Such equipment shall be installed when specified by the booster manufacturer or its authorized representative. In general, this arrangement will be called for to keep the booster motor cool under low flow conditions.

5.10 Submittals

The booster manufacturer or its authorized representative shall submit to the Con Edison Energy Services Representative, the following:

- A) a completed Gas Booster Design Data Sheet (Appendix A of this specification).



<b>NUMBER:</b>	<b>DATE:</b>	<b>VOLUME: 4 and Gas Blue Book</b>	<b>PAGE 5</b>
<b>G-2040-9</b>	<b>6/22/11</b>	<b>Application and Design; Gas Blue Book</b>	<b>OF 7 PAGES</b>



**TITLE: REQUIREMENTS FOR THE  
INSTALLATION OF GAS BOOSTERS,  
MICROTURBINES AND ASSOCIATED  
SYSTEM PROTECTIVE DEVICES**

5.0 **GAS BOOSTER INSTALLATIONS** (Continued)

- ★ B) a job specific one-line drawing of the proposed booster installation. The drawing shall indicate:
  - 1) the location and size of all piping, isolation valves, check valves (including the minimum distance from the booster inlet), pressure switches, pressure gauges, boosters, gas meters; and the type of connection (e.g. flanged; threaded; welded; or stainless steel braided hose.)

**NOTE:** If the low gas pressure switch is shown on the one-line sketch to be in a location **other than** near the gas service point of entry [See 5.5 (B)(2)], the local GDS Department shall be contacted by the ESR for concurrence.

- 2) the size and configuration of by-pass piping, re-circulation loop, and heat exchanger, if required.

5.11 Field Verification

- ★ A) Preliminary Field Check  
Prior to issuing a turn-on request for the gas meter(s) that feeds the gas booster, the Company's Energy Services Representative shall perform the field checks called for in Appendix B of this specification.
- ★ B) Deficiencies
  - 1) If the field checks reveal any deficiencies, the Energy Services Representative shall notify the customer or customer's authorized representative. The turn-on request for gas meters that feed the gas booster shall not be issued until all deficiencies are corrected.
  - 2) Gas shall not be supplied to a booster that lacks the required protective equipment called for in Section 5.5 A) & B). In such case, in lieu of shutting down or denying gas to the entire building, the booster inlet valve may be closed and locked so that other branches of gas distribution piping not fed by the booster may be or remain supplied.



NUMBER:	DATE:	VOLUME: 4 and Gas Blue Book	PAGE 6
G-2040-9	6/22/11	Application and Design; Gas Blue Book	OF 7 PAGES



---

---

**TITLE: REQUIREMENTS FOR THE  
INSTALLATION OF GAS BOOSTERS,  
MICROTURBINES AND ASSOCIATED  
SYSTEM PROTECTIVE DEVICES**

---

---

★ 6.0 **MICROTURBINE INSTALLATIONS**

Gas boosters associated with microturbine installations are subject to all requirements of this specification including the Con Edison-approved check valve and low-pressure switch called for in Section 5.5. These requirements will not be waived even if microturbine units are supplied with integral check valves and low pressure switches.

★ 7.0 **REFERENCES**

Table XVII of Con Edison "Requirements for Gas Service Installations" ("Gas Blue Book")

★ 8.0 **ATTACHMENTS**

Appendix A: Gas Booster Design Data Sheet

Appendix B: Field Verification Checklist

Drawing No. 311296 "Typical Gas Booster Installation"



<b>NUMBER:</b>	<b>DATE:</b>	<b>VOLUME: 4 and Gas Blue Book</b>	<b>PAGE 7</b>
<b>G-2040-9</b>	<b>6/22/11</b>	<b>Application and Design; Gas Blue Book</b>	<b>OF 7 PAGES</b>

**★ Appendix A**  
**Gas Booster Design Data Sheet**  
**To Be Completed By the Booster Manufacturer or Its Authorized Representative**

Project Address (POE): \_\_\_\_\_

**LOAD & PIPING INFORMATION**

- ★1. A) Total # of Boilers \_\_\_\_\_ Total CFH (Min) \_\_\_\_\_ (Max) \_\_\_\_\_  
 B) # and Type of Other Gas-Fired Appliances \_\_\_\_\_ - Total CFH (Min) \_\_\_\_\_ (Max) \_\_\_\_\_
- 2. Gas Service Diameter (From Con Ed Form 2-80) \_\_\_\_\_
- 3. Gas Meter Size & Type (From Con Ed Form 2-80) \_\_\_\_\_
- 4. Gas Pressure Available at Booster Inlet \_\_\_\_\_  
 (4" W.C. @ Head of Service Minus Pressure Losses.  
 Allow 0.5" W.C. For Pressure Drop Through Meter)
- 5. Gas Pressure Required at Manifold Inlet \_\_\_\_\_
- 6. Discharge Piping Diameter \_\_\_\_\_
- 7. Total Equivalent Length of Discharge  
 Gas Piping Including Fittings \_\_\_\_\_
- 8. Total Discharge Piping Pressure Loss \_\_\_\_\_

**★ ADDITIONAL INFO**

**BOOSTER / EQUIPMENT INFORMATION**

- 9. Mfr \_\_\_\_\_ Model \_\_\_\_\_ Flow Capacity (CFH) \_\_\_\_\_ NEMA Location \_\_\_\_\_
- 10. Booster Inlet Size \_\_\_\_\_ Outlet Size \_\_\_\_\_
- 11. Booster Motor HP \_\_\_\_\_ Voltage \_\_\_\_\_ Ph \_\_\_\_\_ Hz \_\_\_\_\_
- 12. Booster Differential Pressure (W.C.) \_\_\_\_\_
- 13. Total Discharge Pressure (W.C.) \_\_\_\_\_  
 (Differential Pressure + 4" W.C.)
- 14. Low Pressure Switch (See Note\*) Make \_\_\_\_\_ Model \_\_\_\_\_ NEMA \_\_\_\_\_
- 15. Control Panel Make \_\_\_\_\_ Model \_\_\_\_\_ NEMA \_\_\_\_\_
- 16. Check Valve (See Note\*) Mfr \_\_\_\_\_ Size \_\_\_\_\_ Min. Allowable Distance To Booster Inlet \_\_\_\_\_
- 17. Manifold Req'd: Y/N \_\_\_\_\_ If Yes: # of Valves \_\_\_\_\_
- 18. Heat Exch'r Req'd: Y/N \_\_\_\_\_ If Yes: Piping Size \_\_\_\_\_ Check Valve Size \_\_\_\_\_

\*\*\*\*\*

Submitted By: \_\_\_\_\_ Date: \_\_\_\_\_ Rev # \_\_\_\_\_

Company: \_\_\_\_\_ Phone: \_\_\_\_\_  
 (Booster Mfr or Authorized Representative)

\_\_\_\_\_/\_\_\_\_\_/\_\_\_\_\_/\_\_\_\_\_  
 Name of Con Edison ESR / Phone / Fax / E-Mail Address

\*Note: Equipment must be listed in Table XVII of the "Requirements For Gas Services" (Gas Blue Book)

**★ Appendix B  
Field Verification Checklist**

**To be completed by the Company's Energy Services Rep prior to release of the gas meters.**

**Project Address (POE):** \_\_\_\_\_

<b>GAS BOOSTER</b>			
		<b>Yes</b>	<b>No (Indicate Action Taken)</b>
1	Has the gas booster been installed?		
2	Does the make and model of the booster match the booster specified on <b>Appendix A (Line 9)</b> ?		
<b>PIPING</b>			
3	Is the size of the booster piping (from the check valve to the booster inlet) in accordance with the booster manufacturer's one-line sketch for this job?		
4	Have the booster isolation valves (if called for on the one-line sketch) been installed? [Note: these need <u>not</u> be Con Edison approved valves.]		
★5	If the one-line sketch calls for by-pass lines or re-circulating lines, have they been installed in accordance with the sketch?		
<b>LOW PRESSURE SWITCH</b>			
6	Has the low pressure switch been installed?		
7	Does the make, model and NEMA rating of the switch match the switch specified on <b>Appendix A (Line 14)</b> ?		
★8	Is the switch located between the gas meter and the check valve at the booster inlet as close as possible to the gas service POE?		
★9	Where there is a branch supply to other gas equipment not requiring boosted pressure, is the switch located on the downstream side of the branch connection as shown on Con Ed drawing 311296, attached?		
<b>CHECK VALVE</b>			
10	Has the check valve at the booster inlet been installed?		
11	Does the make, model, and size of the check valve match the check valve specified on <b>Appendix A (Line 16)</b> ?		
12	Is the check valve located at least the minimum distance away from the inlet of the booster as indicated on <b>Appendix A (Line 16)</b> ?		
13	Does the arrow on the check valve point toward the booster?		

Name of C.E. Energy Services Representative : \_\_\_\_\_

Date and Time of Inspection : \_\_\_\_\_ / \_\_\_\_\_

967112

**REVISIONS**

M. BALDOVIN 3/8/06	1
-----------------------	---

REVISED NOTES.

RAJ 5/17/06

M. BALDOVIN 6/22/11	2
------------------------	---

ADDED FLEX CONNECTOR AND NOTE 5.

D.J. 6/22/11

**NOTES:**

- 1- THIS VALVE MAY BE OMITTED IF THE BOOSTER IS IN CLOSE PROXIMITY TO ANOTHER DEDICATED SHUTOFF VALVE. THE SERVICE HEAD VALVE OR METER VALVE MAY REPLACE THE VALVE UPSTREAM OF THE BOOSTER. THE GAS TRAIN VALVE MAY REPLACE THE VALVE DOWNSTREAM OF THE BOOSTER. THIS NEED NOT BE A CON EDISON APPROVED VALVE.
- 2- CON EDISON APPROVED EQUIPMENT. SEE CON EDISON "REQUIREMENTS FOR GAS SERVICES" (TABLE XVII)
- 3- THE LOW PRESSURE SWITCH SHALL BE WIRED TO THE BOOSTER CONTROL PANEL. THE SWITCH SHALL HAVE A MANUAL RESET AND BE SET TO OPEN AT 3" WC TO SHUT THE BOOSTER OFF.
- 4- THIS VALVE MAY BE OMITTED IF THE LINE IS FED FROM A DEDICATED SERVICE AND APPROVED IN WRITING BY CON EDISON.
- 5- FLEXIBLE CONNECTOR (E.G. STAINLESS STEEL BRAIDED HOSE) IF SPECIFIED BY THE BOOSTER MFR OR REPRESENTATIVE.

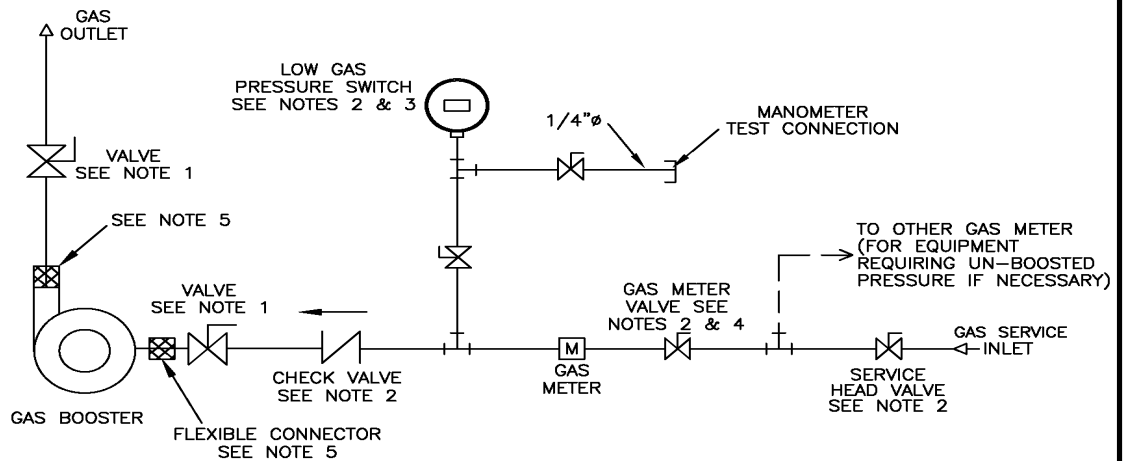

REFERENCE SPECIFICATION G - 2040

**TYPICAL GAS BOOSTER INSTALLATION**

CONSOLIDATED EDISON COMPANY OF N.Y., INC.  
GAS ENGINEERING DEPT

DATE 1/7/98

DWG.

LAST REV. 6/22/11

NO.

**311296 REV. 2**

**5. Gas Equipment Operation:**

Con Edison is not required to supply gas service until the customer's equipment, particularly with respect to the magnitude of increments of load turned on or off and the rate of change of these increments, shall be such as to not impair the quality of service rendered by Con Edison to any of its other customers.

**6. Piping Design:**

The customer shall design his piping system in accordance with the "National Fuel Gas Code" - ANSI z223.1 ("NFPA" 54), local codes, and Con Edison specifications.

**7. Unsafe Conditions:**

Some examples of unsafe conditions are listed below (page 38). If any of these or other hazardous conditions exist, the Con Edison will not provide gas service.

A "Red Tag" warning will be issued and the appropriate valve will be closed and locked until the unsafe conditions are eliminated.

## **Unsafe Conditions**

- Any unit installed without sufficient air for combustion.
- Any leaking gas pipe inside a building that cannot be temporarily or permanently repaired.
- Any space or water-heating appliance that is not properly vented.
- Any venting system used to convey flue gases that is defective, obstructed or inoperable.
- Heat exchangers which are corroded or cracked beyond repair or blocked and which cause products of combustion to enter the arm air distribution system.
- Any leaking appliance inside a building, which cannot be temporarily or permanently repaired.
- Any unit other than a space or water-heating appliance having visual indications of improper combustion.
- Any appliance with a missing or inoperative required safety device.
- Defective or improper wiring, which may cause an unsafe condition on a gas appliance.
- Any space heater or water heater with an inoperative thermostat.
- Open flame burners too close to combustibles.
- Absence of draft diverter or double-swing barometric damper where required.
- Any proper vented appliance developing excessive carbon monoxide, which shall be defined as 0.02% for vented room heater and 0.04% for all other vented appliances, in an air-free sample of the flue gases when tested in an area having a normal oxygen supply.
- Any gas pipe or appliance, which was leaking and has been temporarily repaired.
- Situations where the clearance between combustibles and appliances or vent connectors is less than required but no immediate fire hazard exists.
- Any gas piping of appliance connections identified as improper or inappropriate.
- Vent connectors that have a rusty condition, reduced size or are incorrectly installed but drawing satisfactorily.
- Improperly installed appliances such as those identified in the National Fuel Gas Code.

**8. Signs for New and Upgraded Multiple Services:**

When more than one service pipe supplies any building or units within a building or premises, signs shall be provided, installed, and maintained by the customer both inside and outside the building to indicate the location of the other service(s).

All signs shall be made of durable, weatherproof material, minimum size 8½" wide x 5½" high.

- a. Outside signs shall be permanently mounted on the building directly over or as close as possible to the gas service point of entry. **Examples:** Second Gas Service Located 27 Feet Right of Left Wall on West 57 Street; Second Gas Service Located 34 Feet Left of Right Wall.
- b. Inside signs shall be permanently mounted near each service point of entry, preferably on the wall over the head of service valve. The wording shall indicate the Street/Avenue from which the service pipe enters, as well as identifiable locations with the building. Example: Second Gas Service Located on Lexington Avenue Side In Storage Room.
- c. The appropriate wording, measurements and location for the signs can be discussed and approved by your Energy Service Representative.

**B) SAMPLE SIGNS**

-39-

(7/31/06)

(Outside of Building)

For second gas service entering around the corner:

For second gas service entering on same street:

**Second Gas Service  
Located 27 Feet  
Right of Left Wall  
On W 57 Street**

**Second Gas Service  
Located 34 Feet  
Left of Right Wall**

Minimum Size: 8½-inches Wide x 5½-inches High

Signs shall be provided by the customer, made of durable weatherproof material, and mounted on building wall over gas service point of entry/curb valve location.

**9. Retrofits for Conservation:**

Several measures, which may not be part of the original appliance or its venting system, may be installed for conservation. Gas service to these modified appliances will only be provided if the conversions meet all of the applicable requirements listed below.

**Requirements for Appliance Retrofits**

Modifications	Applications	Notes
Electric vent damper	Central Heating	1, 2, 3, 4, 7, 8
Thermal vent damper	Central Heating and Water Heating	2, 3, 4, 7, 8
Mechanical vent damper	Central Heating	3, 4, 5, 7, 8
Flue gas heat reclaimer	Central Heating	5, 6
Automatic gas ignition system	Central Heating	7
Derating, with or without fixed vent restriction	Central Heating	5
Direct air supply	Central Heating	5

**Notes/Requirements**

1. Allowed in New York City if listed by New York State Department of Labor.
2. Allowed in Westchester if acceptable to the authority having jurisdiction.
3. Can only be installed between the draft hood and the chimney vent.
4. Allowed with gas-design units only.
5. Allowed if acceptable to the authority having jurisdiction.
6. May be installed either upstream or downstream of draft hood, depending on its listings.
7. May be component of original equipment.
8. There must be a label on the modification with the following:
  - a) Name and address of qualified installer of the modification.
  - b) Date modification was made.

**10. Gassing In Customer's Piping:**

- The customer will call Con Edison and make an appointment to have the piping gassed in.
- The customer or the customer's qualified plumber must be available to provide Con Edison personnel access to house piping and must have sufficient help available to conduct the gassing in of customer piping.
- Con Edison will install the meter and verify the integrity of the customer's piping by performing a dial test or pressure test, as appropriate.
- Should the customer's piping fail the integrity test, Con Edison will shut off and lock the gas supply valve.
- The customer will make necessary repairs, and notify Con Edison when the piping is ready to be gassed in. The above steps will then be repeated.

**11. Adequate Air Supply for Gas Equipment:**

Customers will take the necessary steps to ensure that all equipment installed in confined or unconfined space has adequate air supply in accordance with local codes and "National Fuel Gas Code" - ANSI Z223.1 ("NFPA" 54). Con Edison personnel access to house piping and must have sufficient help available to conduct the gassing in of customer piping.

- Con Edison will install the meter and verify the integrity of the customer's piping by performing a dial test or pressure test, as appropriate.
- Should the customer's piping fail the integrity test, Con Edison will shut off and lock the gas supply valve.
- The customer will make necessary repairs, and notify Con Edison when the piping is ready to be gassed in. The above steps will then be repeated.

**11. Adequate Air Supply for Gas Equipment:**

Customers will take the necessary steps to ensure that all equipment installed in confined or unconfined space has adequate air supply in accordance with local codes and "National Fuel Gas Code" - ANSI Z223.1 ("NFPA" 54).